

THE PROFESSIONAL MAGAZINE FOR ELECTRONICS AND COMPUTER SERVICING

ELECTRONICTM

Servicing & Technology

February 2000

Recognizing and correcting the most common VCR defects

What's new in computer software

PROFANX
RCA/GE Color Video
Camcorder Model CC320



Digital versatile disk technologies

U.S. POSTAGE
*****3-DIGIT 787
04 00213563 2008 20020LAJR
TOM KIRKLAND
5907 IVY HILL DRIVE
AUSTIN TX 78759
7 25274 86667 0

Big Screen

Big Profits!

Bring home the cash with in-home servicing of high-end electronics. Quickly and accurately aligning big-ticket items like projection TVs for your customer's total viewing satisfaction can be your best opportunity for profitability. Sencore offers servicing solutions for progressive servicers with portable, durable and reliable test equipment that brings the "best of the bench" to every home.

HA2500 Universal Horizontal Analyzer

Localize horizontal and B+ Supply defects in less time and more profitably than ever before!

- Exclusive "Horizontal Output Load Test" makes setup and testing a snap - even without applying AC power for faster diagnosis
- Patented "ringer" proves the condition of flybacks and yokes in seconds
- Exclusive "dynamic tests" help you analyze the horizontal circuit in powered-up conditions

VG91 Universal Video Generator

This complete all channel RF/IF/MTS Universal Video Generator performance tests and isolates defects in any NTSC video system, including big screen TV systems!

- Proof-positive tests for MTS Stereo/SAP on all channels
- Exclusive and dynamic NTSC video test signals
- Standard, Y/C, composite video, and audio line outputs

SENCORE

www.sencore.com • email:sales@sencore.com

Circle (1) on Reply Card

1-800-SENCORE

contents

FEATURES

- 6 Recognizing and correcting the most common VCR defects** by Bruce Meehl
Here's a rundown of the 15 most common defects of VCRs sold during the 1980s and the 10 most common defects of the VCRs sold during the 1990s, along with some recommended strategies for dealing with those defects.
- 10 Servicing RCA's TX82TV chassis** by Homer Davidson
These sets are small and inexpensive, but they can be efficiently serviced. Veteran technician/author Homer Davidson tells you how.
- 16 Digital versatile disk technologies: Versatility, capacity, and growing popularity** by John Ross
Versatile DVD disks provide permanent, portable storage for huge amounts of information for movies, audio, and computers. Learn more about this technology here.
- 40 What's new in computer software** by Conrad Persson
This article describes a few programs to help you manage contact information, write better ads, learn about finance, market your products and services, write performance reports on employees, and more.
- 46 Speaking about speakers** by Alvin Sydnor
High quality audio has become an important aspect of the home entertainment experience. Here's a rundown on speaker characteristics.
- 53 Zenith Model SM2726EWM** by Steve Babbert
This description of the power supply circuits of this set will save technicians time and aggravation when they encounter one on the bench.

DEPARTMENTS

- 2 Editorial
- 3 Literature
- 4 News
- 15 Products
- 25 Calendar
- 26 Test Your Electronics Knowledge
- 29 Profax
- 39 Photofacts
- 44 Technology: Battelle forecasts strategic technologies for 2020
- 62 Classified
- 63 Reader's Exchange
- 64 Advertisers' Index

ON THE COVER

The huge amounts of information that can be stored on a DVD disk has brought a new dimension to personal computing and home entertainment. DVD allows software manufacturers, for example, to deliver the equivalent of several CD-ROM disks on a single DVD-ROM disk. Moreover, with the right computer and drive, a computer user can even watch a DVD-based movie right on the monitor screen. All of this makes it increasingly important that the monitor is correctly adjusted. (Photo courtesy of Network Technologies, Inc.)



15



16

Editorial

by Nils Conrad Persson

Everybody's getting connected

The internet, once the private domain of "computer geeks," and something of a curiosity for the rest of us, has become part of the mainstream of communications. And it's growing in importance every day. That much was made very clear at the recent Consumer Electronics Show (CES) in Las Vegas.

For example, at this moment thousands of young people are downloading music from the internet into small player devices, or playing back the music that they downloaded on these devices. These devices have no tapes, no disks, just semiconductor circuits that can store a reasonable amount of music.

Millions more people are connected to the internet researching information for term papers, articles, and other writings, looking for the name of a nearby business, trying to find a recipe for tonight's dinner, checking out what's at the movies, looking for a restaurant for Saturday night's evening out, posting an e-mail to a business colleague, or just chatting with a friend. Or engaging in any of hundreds of other information-related activities.

It's probably true that there has been a great deal of hype about the Internet, and there's a lot of silliness surrounding this phenomenon, as there is about any other technological revolution. Still, the Internet has definitely arrived. And it's changing the way people do things. And manufacturers are responding to it.

For example, two of the buzzwords at the 2000 CES were "internet appliance" and "connectivity." In the past, although this has already changed vastly, and is still changing, the Internet was the private domain of computer people because the only way to connect to the Internet was through the use of a "computer." Well, of course, because the Internet is, in fact, a network of computer networks, and only a computer can connect to and interact with that network.

But that leaves a lot of people out who might want to take advantage of what the Internet has to offer: electronic mail, shopping online, research, etc., but who aren't computer savvy, and/or who have no interest in computers. That considerably sized segment of the population has prompted manufacturers to design devices that can be used to access the Internet, but require no knowledge of computers and are easy to learn how to use. Such devices are what the industry terms "internet appliances."

These devices are still computers of some type. They have to be digital storage, processing, and display devices, or they couldn't interface with the Internet. They just don't look like computers, and their functions are simplified so that users don't have to learn to operate a computer.

One such device is a telephone, or answering machine, that also provides e-mail sending and receiving capability. It's extremely limited in terms of its functions, but some people only want to be able to send or receive e-mail to keep in touch with friends, family, or business associates. They don't want to be able to do any of the other things the Internet makes available.

Another Internet appliance is a small box that connects to the

phone line and a TV or monitor. This product is really a simplified computer. It runs only the software needed for Internet access, and that is run from ROM, so the user doesn't have to worry about disks, or any of the protocol necessary to get the software installed and running. Instead of function keys, at the top of the keyboard is a group of keys with easy to understand logos on them. A picture of an airplane means the user presses that to access the site where he can buy airline tickets. Other keys have pictures on them to define their function.

The company that makes these devices is also an Internet provider, so the user of the device only needs to access that site, as a gateway to the Internet.

But Internet access is becoming available everywhere. Some cellular telephones have circuitry imbedded in them so that the user only has to dial an appropriate telephone number and their cellular telephone will connect them to the Internet for certain functions. And personal digital assistants, small handheld computers can now connect to the Internet.

One company, Seiko Instruments, now offers an integrated circuit that simplifies connection to the Internet. Here is a description of what that device offers, from the press release describing the company's brochure about the chip. "The iChip is the world's first stand-alone hardware-based Internet-ready IC. This IC allows Web browsing, e-mail, and networking to be added to consumer or commercial devices easily and inexpensively." The release continues "Developed in conjunction with iReady Corporation of Santa Clara, CA, the iChip permits users to connect to the Internet, or any network that uses the TCP/IP protocol, using their PDAs, organizers, cell phones, or even pagers, as well as many other non-portable electronic devices. Adding Internet functionality to these types of devices is now as simple as selecting any other pre-defined component, such as a resistor or controller."

Of even greater interest to consumer electronics servicing, the brochure goes on "Aside from the portable handheld applications, the iChip can be utilized in remote information access for security and fire alarms, home and building automation, gas and electricity meters, weather and earthquake data, and vending machines and pay phone inventory and status. Other uses include *remote diagnostic testing for home appliances, field service instruments, printers, and copiers.*"

Another interesting note. Even now, the Internet is capable of bringing video into the homes of people who have Internet access. Anyone with an interest in television is looking at the Internet as another way of delivering television/video programming to consumers.

We're not going to draw any conclusions from all of the above. The point of this editorial was simply to let all of our readers know that the Internet is here, for real, to stay, and, just as did the introduction of electric light, the automobile, or the telephone, will have a profound effect on all of us. Stay tuned. ■

ELECTRONIC

Servicing & Technology

Electronic Servicing & Technology is edited for servicing professionals who service consumer electronics equipment. This includes service technicians, field service personnel and avid servicing enthusiasts who repair and maintain audio, video, computer and other consumer electronics equipment.

EDITORIAL

Nils Conrad Persson, *Editor*
(Internet e-mail: cpersedit@aol.com)
Alycia Nicholson, *Associate Editor*
(Internet e-mail: AlyciaEST@aol.com)
Richard S. Moseson, W2VU, *On-Line Coordinator*

CONSULTING EDITORS

Homer L. Davidson, *TV Servicing Consultant*
Victor Meeldijk, *Components Consultant*
John E. Shepler, *Audio Consultant*
Sam Wilson, *Electronics Theory Consultant*

PRODUCTION

Elizabeth Ryan, *Art Director*
Barbara McGowan, *Associate Art Director*
Edmond Pesonen, *Electronic Composition Mgr.*
Dorothy Kehrwieler, *Production Manager*
Emily Leary, *Assistant Production Manager*
Pat Le Blanc, *Phototypographer*

BUSINESS

Richard A. Ross, *Publisher*
Sal Del Grosso, *Accounting Manager*
Ann Marie DeMeo, *Accounting Department*
Judith Erickson, *Office Manager*
Catherine Ross, *Circulation Manager*
Melissa Gilligan, *Operations Manager*
Denise Kells, *Data Processing*
Jennifer Cormagi, *Customer Service*

ADVERTISING SALES OFFICE

Kaprelian & Company, Inc.
521 Illinois Avenue, St. Charles, IL 60174
Tel.: 630-584-5333 Ext. 10 • Fax: 630-584-9289

Bill Kaprelian, *Director of Advertising*
Emily Leary, *Sales Assistant*

EDITORIAL CORRESPONDENCE:

P.O. Box 12487
Overland Park, KS 66212
913-492-4857



Electronic Servicing & Technology (ISSN 0278-9922) is published 12 times a year by CQ Communications, Inc. 25 Newbridge Road, Hicksville, NY 11801. Telephone (516) 681-2922. Periodical class postage paid at Hicksville, NY and additional offices. Subscription prices (payable in US dollars only): Domestic—one year \$26.95, two years \$49.95. Canadian—one year \$36.95, two years \$69.95. Foreign Air Post—one year \$44.95, two years \$85.95. Entire contents copyright 2000 by CQ Communications, Inc. Electronic Servicing & Technology or CQ Communications, Inc. assumes no responsibility for unsolicited manuscripts. Allow six weeks for delivery of first issue and for change of address. Printed in the United States of America.

Postmaster: Please send change of address notice to Electronic Servicing & Technology, 25 Newbridge Road, Hicksville, NY 11801.

CQ Communications, Inc. is publisher of CQ The Radio Amateur's Journal, Popular Communications, CQ Radio Amateur (Spanish CQ), CQ VHF, CQ Contest, and Electronic Servicing & Technology.

Literature

ESD control products catalog

Viziflex Static Solutions offers a comprehensive line of static control products that can help dissipate electrostatic properties whenever people and sensitive electronics equipment meet.

Their new catalog of static control products includes anti-static floor and desktop mats, keyboard touch strips, anti-static sprays, wipes and bags, personal grounding strips for wrist and shoe and a portable field service kit.

Viziflex Static Solution, 16 East Lafayette Street, Hackensack, NJ 07601-6895,
Phone: 1-800-SEELS, Fax: 201-487-6637,
Website: www.viziflex.com
Circle (92) on Reply Card

T&M catalog

LeCroy Corporation has released its 2000 catalog available on both CD and in hard copy. The new catalog features complete descriptions of the company's latest digital and analog oscilloscopes, probes and accessories, signal sources, waveform digitizers, and high-energy physics instrumentation, as well as informative application briefs.

Among the products included in the new catalog are the Waverunner series of digital oscilloscopes, LC684D digital oscilloscope, DDA-125 disk drive analyzer, jitter analysis software, power measurement tools and telecommunication testing solutions. Also published in the catalog is a new series of application briefs that have been highly popular with engineers. New applications outlines include measuring and analyzing jitter in high-speed devices, as well as conducting highly accurate analysis of power supplies.

LeCroy Corporation, 700 Chestnut Ridge Road, Chestnut Ridge, NY 10977-6499,
Phone: 1-800-4LeCroy, E-mail: contact.corp@lecroy.com,
Website: www.lecroy.com

Circle (93) on Reply Card

Flat-panel display info on-line

InterLingua.com, Inc., a source of information on flat panel display technology from Asia, has launched a new

website dedicated to the FPD industry. FPDonline.com offers visitors current and archival information on the leading technologies, business trends, product introductions, corporate tie-ups, etc.

"More than half the information is available at no cost to visitors of the website," says Jack Bernstein, President of InterLingua.com and Editor of the company's electronic publication DISPLAY: The E-mail Newsletter, "and the rest is available at ridiculously low cost."

The no- and low-cost information available on the website is drawn from leading Japanese sources including: *FPD Intelligence Magazine*, *Nikkei Microdevices' Flat Panel Display Yearbooks*, a variety of manufacturing and equipment related research reports from the prominent Fuji Chimera Research Company, and the company's own e-mail newsletter.

The site will be expanding the editorial content with additional information from Asia throughout the new year. The company is forming relationships with a number of other publishers and research houses in Japan, Taiwan, and South Korea.

In addition to the articles and research reports, visitors to the website now and in the coming year will find: a Technology forum for discussions of topics of interest to those in the field; a searchable database of published patent filings from Japan in the display field; a searchable on-line directory of companies in Japan and in various aspects of the field; information about organized study tours and group travel to Japan; information about customized research projects seeking partners; assistance in transactions for purchase of products/services in Asia; assistance translating correspondence, contracts, spec sheets, manuals, etc; and advertising, links, and more.

InterLingua.com, Inc., 423 S. Pacific Coast Hwy., Redondo Beach, CA 90277,
Phone: 310-792-3636, Fax: 310-7923642,
E-mail: interlingua@interlinguacom.com,
Website: <http://interlinguacom.com>

Circle (94) on Reply Card

Television manufacturers urge FCC to dismiss Sinclair petition

The Consumer Electronics Association (CEA) along with 13 digital television manufacturers has reaffirmed their support for the current digital television (DTV) broadcast standard. In a letter to the Federal Communication Commission (FCC) on November 10, CEA members representing the major digital television manufacturers urged the Commission to dismiss the Sinclair Broadcasting Company's petition to re-examine the standard and allow the DTV transition to continue.

In the letter, the manufacturers note that, "The 8-VSB Digital Broadcast Standard . . . best meets the technology requirements of the digital transition."

"To revisit the standard at this stage of the transition," they continue, "will jeopardize the future of digital television. Moving forward now will ensure that consumers will soon have access to a wide array of products, additional DTV applications, and in terms of cost, the benefits of mass production."

CEA and its members also pledge their commitment to providing consumers with the highest quality DTV products available.

"Second- and third-generation receivers will incorporate the latest technology and will demonstrate continuous improvements in quality and performance — hallmarks of our exciting industry," they wrote.

Speaking at the Association for Maximum Service Television's (MSTV) annual DTV Update, CEA President Gary Shapiro said, "The current standard was developed as the result of a multi-industry, scientifically rigorous process. Nearly 100 broadcasters have made the transition and DTV products are being sold at retail across the United States. The momentum behind DTV is strong. Now is not the time to revisit the standard."

CEA filed a Motion to Dismiss Sinclair's petition with the FCC. After filing a response to CEA's Motion, Sinclair sent a retraction to the FCC, admitting that their filing had overstated broadcaster support for their initial petition. Specifically, the letter stated that America's Public Television Stations (APTS) and Paramount do not support the Sinclair petition.

"Unfortunately, there is a lot of misinformation being circulated around this issue," said Shapiro. "The initial standard was developed based on the facts — to reopen it now based on hyperbole and misinformation would be a mistake."

DTV sales maintain explosive pace

Factory sales of digital television (DTV) topped 20,000 units for the first month ever in October 1999, bringing the total year-to-date sales to 74,847, according to numbers released by the Consumer Electronics Association (CEA). Total sales since introduction now equal 88,023 units.

Actual DTV sales in October totaled 21,432 units, an increase of 42 percent over the previous month's record setting mark of 15,060 units. The increase continues a yearlong trend in sales, in which each quarter shattered the mark set in the previous

quarter. In the third quarter alone, sales increased by 81 percent over the second quarter. Trend analysis also shows that during the previous three months (August through October) sales increased by more than 270 percent — 27,237 units — over the previous three months (May through July).

"DTV is no longer the wave of the future, it is here and now of cutting-edge television technology," said CEA President Gary Shapiro. "It's no coincidence that the huge growth in DTV sales coincided with an expansion in DTV content. While the progress made thus far is strong, we need more high-quality content to continue the momentum and bring the digital future to consumers today."

CEA has estimated DTV sales to total 120,000 sets from introduction through the end of 1999. Todd Thibodeaux, CEA's vice president of Market Research commented, "The very strong results posted in October, combined with two traditionally big industry months to come, place us right on track to meet our 15 month projection of 120,000 in sales. It also keeps momentum going into 2000."

CEA further estimates sales to reach 600,000 in the year 2000, and projects that the first 10 million sets will be sold by 2003, the next 10 million in 2004 and 2005, and 10.8 million to be sold in 2006.

CEA urges quick Senate action on SHVA

The following statement was issued in November by Consumer Electronics Association (CEA) President Gary Shapiro regarding the Satellite Home Viewer Act (SHVA) passed by the U.S. House of Representatives:

"The Consumer Electronics Association congratulates the conferees for finalizing and the U.S. House of Representatives for passing the Satellite Home Viewer Act (SHVA). This bill helps level the playing field to allow digital broadcast system (DBS) companies to compete with cable providers and provide consumers a true alternative to cable and over-the-air broadcasts.

"We have long believed that the ability of DBS subscribers to receive local network signals is critical for the continued success of the home satellite market. The six-month phase-in period for retransmission consent helps meet this goal, allowing consumers to immediately obtain the benefits of 'local-into-local' service while broadcasters and satellite providers negotiate retransmission agreements."

"This legislation would not have been made possible without the leadership of Congressman Tom Bliley (R-VA). Additionally, we appreciate the efforts of all of the House and Senate conferees who worked to resolve differences in earlier versions of the bill to craft a solid and important piece of legislation that provides consumers with a true choice. We urge the Senate to act quickly and pass this legislation and President Clinton to sign it into law. Quick passage of the bill into law will bring strong opportunities and benefits for consumers as well as current DBS subscribers, manufacturers, and content providers during the holiday season and beyond."

CEA announces cable compatibility specification

Following extensive discussions with the cable industry, the Consumer Electronics Association (CEA) has announced that it had issued a specification for compatibility requirements for digital television (DTV) receivers and digital cable systems. This specification, when implemented, will allow Americans to receive in-the-clear, premium and pay-per-view digital cable programming on their DTV receivers, as well as today's basic cable analog channels, all without the need for a set-top box.

"This specification represents a considerable achievement and is a major step toward cable-compatible DTV. It is a pro-consumer specification that will allow Americans to receive popular cable services directly through their DTV receivers without the need for a cable set-top box," stated CEA President Gary Shapiro.

Shapiro indicated that the specification was in harmony with the network interface (OCI-N) and point of deployment (POD) specifications recently released by CableLabs which seek to describe how a cable system will send its digital signals to DTV sets. Shapiro also emphasized that with the new specification, copy protection is assured on cable-compatible DTV sets.

Shapiro pointed out that there remain some areas where the cable and consumer electronics industries disagree, most notably with regard to cable's insistence that an IEEE 1394 set-top box interface be included on every DTV set.

"Our industry developed 1394, and manufacturers will produce 1394 equipped sets for consumers who want them," said Shapiro. "At the same time, it doesn't make sense to include a 1394 set-top box interface on every DTV set, since more than 50 percent of consumers today prefer to attach their cable directly to their set without a box. We don't want to broaden the digital divide by forcing Americans to pay more for every DTV set to get features they may not want or use."

Shapiro noted that the specifications merely mark the first step in defining the basis of a range of future cable-compatible products.

"We look forward to continuing to work with the cable industry to develop further specifications that bring new capabilities — such as full two-way, interactive services — to American consumers," stated Shapiro.

In anticipation of these developments, CEA announced the formation of a new engineering committee, R-8 (Cable Compatibility.)

"The scope of this committee is to establish standards and bulletins necessary for the purpose of defining connectivity and interoperability between digital cable systems, cable compatible DTV receivers and related consumer electronics devices," said Ralph Justus, acting vice president of Technology and Standards for CEA.

The inaugural meeting of the committee was set for December 1999 in Washington, D.C. All potentially affected industry segments were invited to send technical representatives to participate.

CEA working to clarify DTV definitions

The Consumer Electronics Association (CEA) outlined steps being taken by its Video Division Board to expand existing vol-

untary industry definitions for digital television.

"Now that DTV is a market reality and consumers have access to a broad array of digital television products, we realize that the original definitions must be extended to address the full range of new products available to consumers," said CEA President and CEO Gary Shapiro. "Our goal is to simplify the different levels of DTV products and provide manufacturers and consumers with uniform terminology to ensure that consumers can make informed DTV purchasing decisions."

This effort, part of an ongoing process which began in June of this year, follows a Video Board vote in October 1999 reaffirming the definitions for digital television products originally issued in January 1998. The Video Board agreed, in a resolution unanimously adopted by its members, that NTSC-only products (scanning frequency of 15.75Khz) should not be marketed as "having any particular DTV capability or attributes," allowing consumers to distinguish between analog and digital television products. The Board also embraced a new definition for audio products compatible with DTV (DTV audio ready).

The Board is developing additional definitions to describe the various performance levels of DTV and the component nature of products available. A technical working group has been appointed to make recommendations to assist the Video Division Board in developing these definitions. Since DTV was introduced in late 1998, the industry, in response to consumer demand, has greatly expanded consumer choice in DTV product offerings. The industry expects to introduce additional terminology addressing these product offerings in 2000 and as other new DTV products are introduced into the marketplace.

"As the industry develops, it is important for manufacturers and retailers to clearly communicate to consumers the features and benefits of new products," said Shapiro. "The additional definitions under development, along with a commitment from manufacturers to clearly label NTSC-only products, will provide consumers with terminology that makes sense and allows them to make smart purchasing decisions."

Stereo sound is an increasingly vital component of video entertainment

Factory-to-dealer sales of televisions utilizing stereo sound were up yet again in October of 1999, according to the Consumer Electronics Association (CEA - formerly CEMA). Sales of stereo televisions increased at their highest rate in the previous four months, totaling almost 1.4 million units and representing an 8.2 percent increase over October 1998 figures. The continued growth brought year-to-date sales of stereo televisions to just over 10 million units, up 3.7 percent over the same period in 1998. In the year-to-date figures, stereo televisions represent more than 53 percent of total analog television sales.

"The continued increase in sales of stereo televisions points to consumers' ever growing desire for a complete audio/visual experience," said Gary Shapiro, president of CEA. "We maintain that audio is the soul of the system, and believe that consumers' desire to enhance their viewing experience through sound will fuel interest in other home theater technologies, such as DVD, digital audio and even high-definition TV." ■

Recognizing and correcting the most common VCR defects

by Bruce Meehl

In every type of consumer electronics product, certain failures are more common than others. Some parts of the products work harder, handle higher voltages or currents, or are not designed as robustly as they should be. Servicing these products can be made more efficient if the technician knows where in the product to look when certain symptoms appear.

Interestingly, because the design of products changes over the course of the years, the defects that were common during one period of time may become less common, and another set of defects may become more common. This is true of failure modes in VCRs over the past two decades.

This article will provide a list of the 15 most common defects of VCRs sold during the 1980s, and the 10 most common defects of VCRs sold during the 1990s, and will recommend strategies for dealing with those defects.

The 15 most common VCR defects during the 1980s

The following 15 problems are the most common defects that repair shops see from VCRs made in the 80s. You could say they are also somewhat common to all VCRs. You may access a database of VCR defects by brand and model at no cost on the Fixer Corp. website at <http://www.fixer.com>. If the problem you're concerned with does not show up in that database, there is a good chance it may be one of these. Out of all the hundreds of things in a VCR that could fail, it usually turns out to be one of these 15. You could have one of these problems and not even know it.

Many of the following are just too common to be placed in the database pages. For example, a reel belt in a capstan reel drive mechanism (found in over 90% of all VCRs) will develop the same symptoms in nearly all of them.

The 15 most common problems that plagued VCRs sold during the 1980s are the following:

1. Dirty heads
2. Idler
3. Belts
4. CPU reset
5. Capstan bearings
6. Roller guides
7. Antenna block
8. Foreign objects caught in mechanisms
9. Relays
10. Tape end sensors
11. Reel sensors

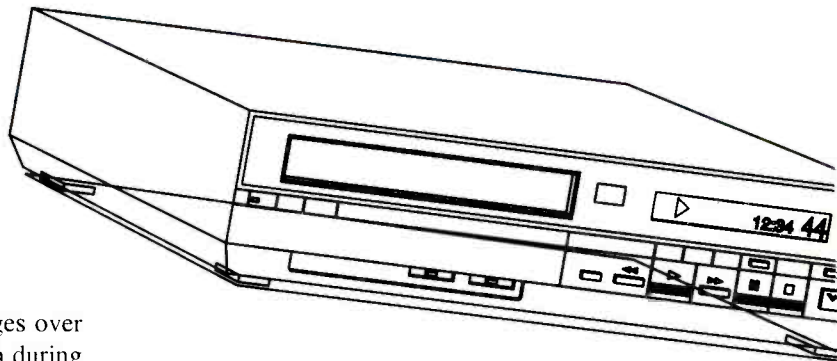

12. Power supply integrated circuits (IC)
13. Cassette carriages
14. Mode switch
15. Record timer

Figure 1 is a generalized picture of the path of the tape through the VCR.

Dirty heads

The symptoms of dirty VCR heads are these:

- Sound is OK
- Picture is snowy. All areas of the picture have equal amounts of snow and the intensity of the snow varies depending on how dirty the heads are. Often it can be so snowy you can't see the picture.
- If the VCR has video muting (blue screen appears when no picture information is present), you will have a solid blue screen.
- It happened suddenly. It did not start out a little snowy and get progressively worse over a period of months. Everything was fine and suddenly everything went to snow.
- Picture went out when tape got snarled up in the machine.

With these symptoms, it's most likely your video heads are clogged. This happens most frequently when you rent movies. A certain number of previous renters have defective VCRs that can put substantial contaminants on the tape. You rent that movie and guess what? Your heads are now gunked up.

The cure to this problem is to clean the heads.

Idler

Symptoms of a defective idler are the following (see Figures 2 and 3 for top and bottom views of a typical VCR mechanism):

- The VCR eats tapes. Capstan pulls tape off the supply reel but the takeup side can't reel it in.
- Won't rewind, sometimes intermittent.
- Shuts off sometimes.
- In early failure stages, while playing, the take-up reel inside the cassette may behave erratically.

Meehl is consumer electronics servicing technician and operator of FixerCorp website.

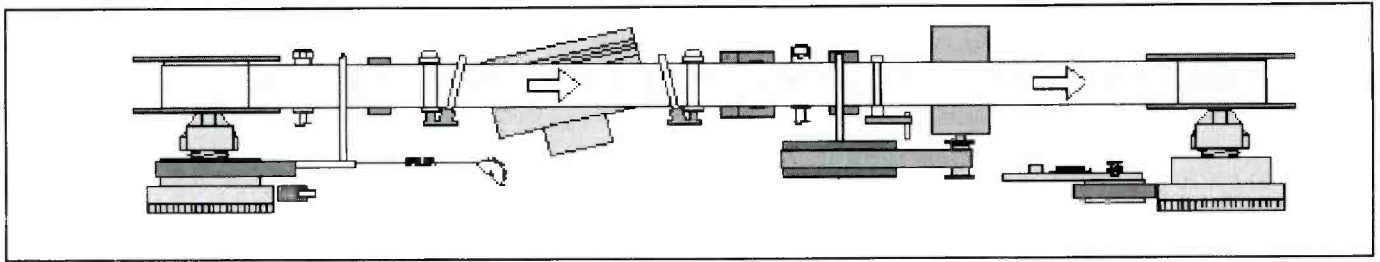

Figure 1. A generalized drawing of the path of the tape through a VCR.

- When you press stop, the guide rollers retract without pulling in the tape.

These problems are caused by a worn idler. Older VCRs have an idler that uses a rubber tire. Over the years, a slow chemical reaction occurs on the surface of the tire. This process results in a glazed surface, causing loss of traction. With a dummy cartridge, you can see that the idler does engage the reel table, but if you grab the reel table with your hand, you find there is little torque. Without traction, the tire slips against the reel table. If you push the idler into the reel table with your finger, it will work, but only as long as you keep your finger on it. Often all you need to do is replace the tire.

The tire can be easily removed. It's not glued or permanently fastened in any way. A small flatblade screw driver is a big help in removing the old one. In fact, you can turn it inside out and remount it that way. This is not recommended as a professional fix since there are no treads on the inside wall and the fact that the rubber has a lot of years of deterioration on it, you will be lucky to get a few months out of it.

Newer VCRs have a gear instead of a tire. Although gears are much more reliable, they still have problems. Usual problems with gears are warping or loss of tension. The plastic retaining cap over the spring sometimes cracks. Without sufficient tension, the idler tends to get caught between the reels. This can be easily seen if you have a dummy cartridge. Gear driven idlers are one piece, so replacement involves the entire idler.

Belts

Symptoms of defective drive belts are listed below.

- Reel belts — an early sign of reel belt weakness is when a T-120 cassette (6 hours) during rewind shuts off before it rewinds all the way. Cassettes with less tape work normally. This belt causes few other problems.

- Tape load belts — VCR may load tape around video drum. At that point, insufficient traction results in not being able to complete the load cycle. CPU then issues a shutdown command. Sometimes, these belts may squeal when slipping.

- Flat capstan belts — these belts will work fine until they physically fall off.

- Cassette carriage belts — rarely ever fail

- Counter belts — these are usually extra thin belts that are used to turn the counter or the reel sensor pulley. The VCR will shut down if the counter is not changing or incrementing. These belts are usually found on older VCRs.

Belts can cause a number of symptoms depending on which belt is failing. First, inspect for belts that may have broken or popped off. Then closely scrutinize for cracks or glazing. Next,

check for elasticity by stretching them about 25% and see if they return to their original size. If in doubt, you may want to replace all of them. They are now inexpensive and easy to replace on most models. Like idler tires, rubber belts degrade with age whether you use them or not.

CPU reset

VCRs are incredibly complex products with a processor, much like a small computer, that controls the functions. On occasion, the central processing unit on a VCR becomes confused and won't operate properly or at all. When this happens, you have to reset the CPU.

Simply disconnect the ac power plug for about 30 seconds and then plug it back in again. This resets the CPU. Turning the VCR off with the power button won't reset the CPU.

Resetting the CPU can solve a number of problems. Any time a VCR appears to be dead or doesn't respond to anything, try resetting it. Any time it behaves weird, like the channel indicator locks up or the clock goes to all 8's, try resetting it. This phenomenon occurs a lot more often than most people think. The primary cause is believed to be static electricity and power surges. Fortunately, resetting fixes most of these problems.

Capstan bearings

The capstan is the component that pulls the tape through the VCR's tape path at a constant speed. If the bearings in this component become defective, it can cause a number of problems, as described below.

- VCR may be playing fine and then suddenly the tape speed slows and eventually shuts off (noise bars are traveling though the picture vertically when this is occurring). The audio slows and may waver.

- The picture may also suddenly freeze (as if someone pressed the pause button), and then shut off.

- Press play and the VCR will go again, but for a much shorter time and stop again.

- The problem always appears on the SP speed and almost never on the EP speed.

- Bearing may emit a squeaking noise.

To determine for sure if the capstan bearing is defective, put a drop of oil on the bearing and run it a few minutes. If a substance that looks like black pepper comes up out of the bearing, you definitely have a bad bearing.

The easiest way to positively identify a bad bearing is to put one small drop of oil on it and see if the symptoms vanish. It's easy to get to from the top. The capstan shaft comes up through it. Sometimes there is an oil seal on top of it. You can

usually pry it up slightly to get the oil underneath it. Remember, just a drop. Be sure no oil goes up the shaft. That is not good for the pinch roller or the tape. It might be a good idea to wipe the shaft thoroughly with a lint free paper towel or rag. The oil may even fix it for a few months, but eventually the bearing will need to be replaced.

Roller guides

If the roller guides become misadjusted or badly worn, there will be horizontal lines in picture. The tracking control won't cure this problem. The items below describe details of what can cause this problem and offer some cures.

- Set screws come loose allowing height adjustment to wander. To confirm this, grab the roller guide with your finger and thumb and see if it can be easily twisted. If so, a re-alignment is in order.

- Tape is running below the shelf on the video drum. Height adjustments are tight and the Roller Guide is tight against the V-stop. To solve this problem, notice that there are two press fit pieces in the roller guide assembly that have slipped. Rebond the parts and re-align.

- Angle pin on roller guide assembly missing. If they are loose, there is a good chance they will stay in until the first time you turn the VCR over to remove screws or whatever. With the cover off, confirm their presence. If missing, they usually stay in the machine somewhere. If found, simply put a small drop of super glue on the pin and press it into the hole on the assembly.

- Roller guide not making contact with V-stop. This problem is usually caused by a linkage problem or by a foreign object caught in the V-stop.

Antenna block

In many VCRs, the coax connector on the antenna block is flimsily manufactured. The symptom of this problem is that the coax connector falls off. This can happen if someone yanks on the coax cable a little too hard. Also some VCRs are manufactured so cheaply these days that it is possible they can fall off all by themselves over time.

Unfortunately, you just can not glue these back on again. These are attached to a metal box inside the VCR. Inside the box is a circuit board usually consisting of the modulator circuits. When these connectors come off, they must be reattached from inside the metal modulator box. It can be done, however, but it requires good soldering skills and can be very time consuming. It is usually much easier to replace the entire modulator itself. Sometimes, this portion of the VCR is referred to as the Modulator Block.

Foreign objects caught in mechanisms

Objects that cause damage to VCR mechanisms come from two different sources: those that get in there by accident, like labels coming off of cassettes, and things that are inserted in there by small children; things like toys, rocks, crayons, and food. When one child was asked why he put a sandwich inside the VCR, his answer was he did not want the cat to get it.

Top loaders are more prone to strange objects because whatever is on top has a chance of accidentally falling in. Usually

these objects cause mechanism jams that trip your VCR's shutdown mechanisms. Anything caught in the roller guide slides will not allow the guides to load up correctly, causing a poor jumpy picture with noisy lines in it. With the cover off, a careful examination of the mechanisms will usually reveal any foreign objects that do not belong inside. Simply removing them is usually all that is necessary to complete the repair.

Relays

Relays, often found on older VCRs, are notorious for causing trouble. Relays were commonly used in head switching and audio circuits. The problems are mostly with the relay contacts. Over the years, the surfaces of the contacts degrade until they reach a point where they can no longer complete a circuit. Head switching relays were standard in older four head VCRs. The position of the relay determines which pair of heads to use.

A typical symptom of a bad head switch relay is a good picture at one speed, but a distorted picture when the VCR is played at another speed. What happens is that when the relay is in one position, it is making good contact for both heads, but in the other position, only one head is getting a good connection. You can usually confirm a bad relay by pressing on it to see if it momentarily corrects the problem. Audio relays were used mostly in portable VCRs and are the first thing you suspect when there is no sound or the VCR does not record sound.

Tape end sensors

All VCRs have two tape end sensors, one for supply and one for takeup. Their job is to sense the transparent end of the tape (or a broken tape) and stop the VCR when the tape is fully played or rewound. Operation of these sensors is based on a beam of light that comes from the center of the cassette, goes through it, and hits the End Sensor. Depending on whether the beam hits tape or clear tape leader, determines if the sensor is tripped or not. For this discussion, it may be helpful to have a VHS cassette in front of you to observe.

The large round hole you see in the center of the bottom side is for an infrared lamp to poke up into it when the cassette loads into position inside the VCR. It shoots a beam of infrared light through the cassette in two different directions, exiting through a small hole on opposite ends. These holes can be seen if you open the cassette lid (you will have to release the catch on the right end). From there, the light travels on to the End Sensors on the carriage side plates.

Inside the cassette, notice the clear leader that attaches to the reel hubs on each end of the tape. When the tape gets to the end, this clear leader allows infrared light to shine through and trip the End Sensor. The End Sensor is like a switch. When light shines on it, the switch is on. When there is no light, the switch is off. This on/off information goes to the CPU where it is processed. During PLAY, RECORD, or FAST FORWARD if the Supply End Sensor is tripped, the VCR goes into REWIND mode. During REWIND, if the Takeup End Sensor is tripped, the VCR goes into STOP mode.

Following are symptoms that you may observe if there are problems with the tape end sensor.

- VCR mysteriously goes into REWIND mode while playing.

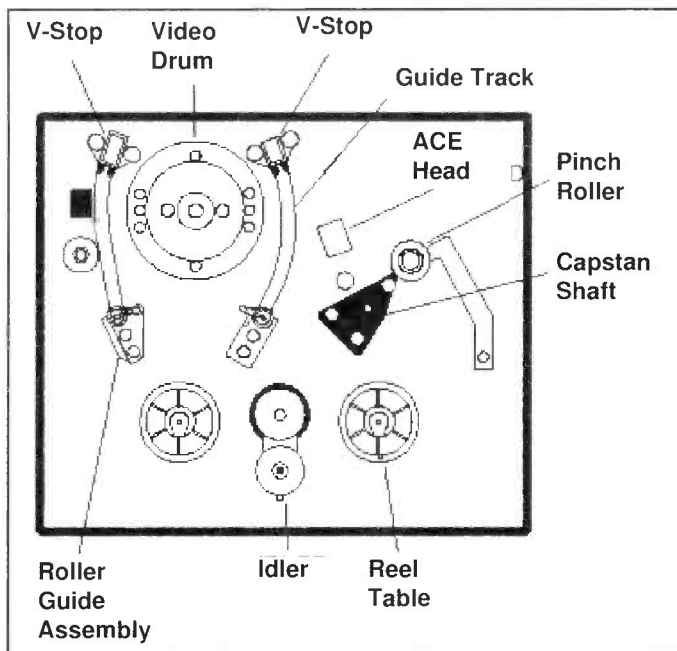

Figure 2. The top view of a typical VCR mechanism.

- Tape ends come off the hubs inside cassettes. With cassette rewinding, observe the tape as it gets to the end. It should stop gracefully. If it continues to struggle, it's most likely the sensor is defective.

- While trying to load a cassette, the VCR ejects it. Some VCRs use these sensors to tell the CPU if there is a cassette loaded. If a sensor is failing, the CPU thinks there is a cassette already loaded.

- Cassette loaded indicator (if it has one) may be illuminated with no cassette inside.

- If you have a voltmeter, measure the two pins on the sensor. One is ground and the other should be about 5V with no light on the sensor. With light on the sensor, it drops to near 0V. With your finger as close as possible to the sensor, cover and uncover the sensor and see if the voltage varies like that.

Warning! With the top cover of the VCR off, room light can confuse troubleshooting efforts. End Sensors were designed to be energized by the light from an infrared lamp. However, room light can also affect them. It goes straight into the sensor and alters voltage readings. If you measure the voltage output of the tape end sensor, instead of near 0V to about 5V, you might get something like near 0V to about 2V and think you have a defective sensor. Be careful. There is a listing in the database for sensitivity with the top cover off. Following are a couple of suggestions you may want to adhere to.

- Make sure there is no sunlight in the room. Sunlight contains a huge amount of infrared light. Close the curtains or wait until nightfall if necessary.

- Use as little light as possible. For example, use only one small lamp and place it clear across the room. Shield your work from the light with cardboard. Tape it in place if necessary.

End Sensors are famous for being intermittent. If the VCR being serviced is experiencing any of the above symptoms, it may be a good idea to replace both of them. They are inexpensive and not that difficult to replace on most VCRs. Some soldering is required to make this repair.

Reel sensors

The symptoms of a reel sensor problem is that nothing appears wrong in the tape transport except:

- The VCR shuts off after about 5 seconds, counter is not changing. Definitely a defective reel sensor.

- VCR shuts off after about 5 seconds, counter is changing. Most VCRs use just one reel sensor under the takeup reel. However, some use two. It's possible the other one could still be the culprit.

- The fact that the VCR works normally for about 5 seconds before shutdown, is a strong clue for a defective reel sensor.

VCRs need to have a method of sensing reel rotation. If the tape is not being reeled in, you could find hundreds of feet of tape all over inside if it were not for this sensor. Older VCRs use a belt driven sensor. It's connected by belt to the reel table. Usually if there was a problem, it was always the belt. Newer VCRs use photo-sensors. They are placed under a reel table that has reflective squares on the bottom. These reflective squares cause the sensor to turn on and off as the reel rotates. As long as the CPU sees these on and off pulses, it's happy. If for some reason the pulses are not there, the CPU thinks the reel is not rotating and issues a shutdown command. The most common problem is failure of this sensor. The cure is replacement of the sensor.

(Continued on page 56)

2 USERS CONTROL 8 PC, SUN & MAC COMPUTERS



Clear Display
at 1900 x 1200

- Available in sizes up to 8 users and 32 computers.
- Users have independent or shared control of up to 512 computers with optional multiplexor.
- Plug-in modules can be added or changed in the field.
- Supports laptop computers and Intellimouse.
- Smooth and responsive mouse movement.
- All keystrokes are translated across platforms - including Sun and Mac "Power" keys.



MULTI-USER
MULTI-PLATFORM



USB



PC
compatible



SPARC
International
Member



Mac

FREE CATALOG!

NTI

NETWORK TECHNOLOGIES INC
 1275 Donner Dr • Aurora, OH 44202
 330-562-7070 • 800-742-8324 • FAX: 330-562-1999
 E-Mail: sales@ntil.com • www.ntil.com

Circle (66) on Reply Card

Serviceing RCA'S 7X82 TV chassis

by Homer L. Davidson

Typical problems encountered in a small 13 inch RCA TV include a dead chassis, an output transistor that runs red hot, chassis shutdown, a set that pulses off and on, and vertical and sound problems. Service problems such as this might be found in both the RCA TX82 and TX81 chassis. Both chassis are quite familiar to technicians, and have similar circuits. In these sets, the breakdown of several different diodes in the secondary power supply circuits results in many different symptoms.

The 2.5A fuse (FP01) might become shorted or open as a result of defective components in the raw dc power supply and horizontal circuits. When components become shorted or leaky in the fly-back power sources, FP01 might not open or appear shorted. The chassis might have shorted diodes in the secondary voltage sources but the line fuse doesn't open. In some cases, small isolated resistors in the secondary voltage circuits might burn open as a result of leaky or shorted diodes.

The dead chassis

As in most TV chassis, in the TX81 and TX82 if the horizontal output transistor (HOT) becomes leaky or shorted this not only blows the ac line fuse, but damages several other components as well (Figure 1). The shorted transistor (TP10) might destroy either RP30 or RP31 (0.07 Ω) resistor in the emitter circuit. TP10 can be destroyed by a leaky flyback LP04. Suspect a defective horizontal output transformer when the body of the winding runs red hot. Replace defective transistor TP10 with an exact replacement, part number 198794. A quick voltage test across the main filter capacitor (CP31), a 330 μ F electrolytic, can determine if the raw power supply is operating normally.

Go directly to the low voltage secondary circuits when the chassis is dead. Check diode DP20 in the 22V source that feeds the vertical circuits to see if it

Davidson is a TV servicing consultant for ES&T.

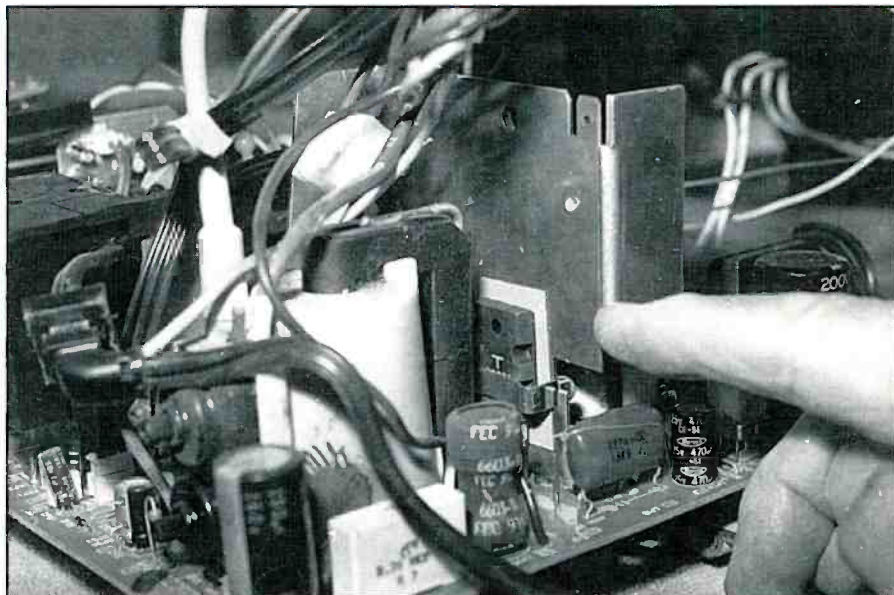

Figure 1. Horizontal output transistor TP10 can cause intermittent shutdown or a dead chassis.

is leaky or shorted. If you replace the diode with part number 198590, and find that the voltage output of this supply is still low, suspect a leaky vertical output IC (IF01) in the vertical output circuits. Check resistor RP53 to see if it is open. Also check electrolytic capacitor CP23

(1000 μ F) in the 22V source with a capacitor tester (Figure 2).

Before testing the capacitance of capacitor CP23, discharge it completely across the two terminals. Clip an alligator clip-lead across the electrolytic capacitor to make sure it is completely

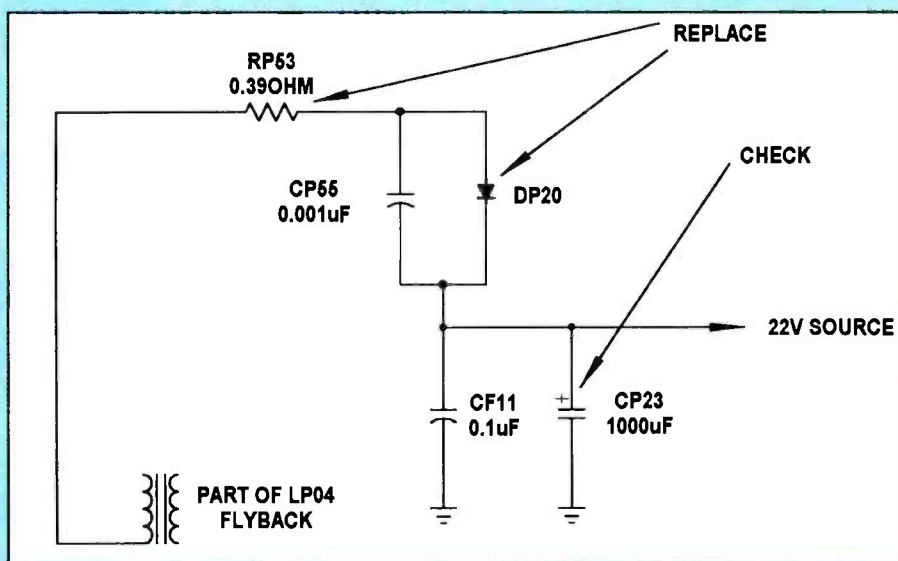

Figure 2. Replace RP53 (0.39 Ω), DP20 diode and Test CP23 electrolytic to cure a dead chassis symptom.

discharged. You should do this with any electrolytic capacitor. Check the condition of the capacitor with a capacitor tester or ESR meter. The ESR capacitor tester can be damaged if the electrolytic capacitor is not fully discharged.

If diode DP36 in the horizontal TP06 Amp and TP09 Shaping circuits develops leakage or becomes shorted, this can cause a dead set. The Comparator Amp and Shaping transistors are in the horizontal drive circuits ahead of the horizontal output transistor. Check for an increase in voltage at the collector terminal of TP06 and base of TP09. The 8.5V source from the flyback circuits feed the horizontal drive transistors.

In the same shaping circuits, check diodes DP08, DP16, DP15, and DP30 for leakage. While in the circuit, test electrolytic capacitors CP07 and CP08. A leaky CP07 (10 μ F) capacitor has been known to cause a dead chassis symptom (Figure 3). Critical diode tests and in-circuit capacitor tests can locate a defective component causing a dead chassis.

Hot output transistor

Most horizontal output transistors that run excessively warm after a few minutes of operation can be caused by an open electrolytic capacitor in the driver transformer circuits or a defective flyback. Insufficient drive voltage to the

horizontal output transistor can soon destroy the output transistor.

Improper voltage supplied to the Comparator, Amp, and Shaping transistors can also cause TP10 to run red hot. Check the supply voltage feeding these three transistors. Go directly to the secondary 8.5V source after replacing the horizontal output transistor if the transistor runs red hot.

Replace leaky DP12 found in the low voltage circuits, even if the diode tests okay after removal from the circuit. Replace DP12 with an exact manufacturer's replacement, part number 198590. Replace the flyback transformer (LP04) if TP10 still runs red hot after replacing DP12 (Figure 4).

Shutdown problems

TV shutdown problems in the TX82 chassis includes these variations: the chassis turns on and then shuts down, or comes up with a bright picture and shuts down, or intermittently shuts down. Most of these shutdown problems are caused by defective diodes and electrolytic capacitors in the secondary low voltage sources. Check the suspected diodes for leakage and check any associated electrolytic capacitors to see if they are open circuited. Remember the horizontal circuits must function before secondary voltage sources are available.

Suspect diode DP18 in the 12V source

of the flyback when the TX82 chassis begins to start up and instantly shuts down. Check resistor RP68 (0.68 Ω) when DP18 is found to be shorted. Both DP18 and RP68 might be found burned open after the diode has become shorted. DP18 supplies voltage to the 12V, 9V, 5.5V, and 5.1V sources. TR02 (Vcc switch) supplies a 5.1V voltage source to the FM radio circuits.

Suspect CP15 (12 μ F) electrolytic within the horizontal supply source (8.5V) when the chassis comes on and then shuts down. Check CP15 with a good capacitor tester or the ESR meter. If the ESR meter pointer is in the yellow or red area when testing any electrolytic capacitor, replace it (Figure 5).

In some TV chassis when the screen became excessively bright and then the chassis shuts down, the cause is a defective picture tube, or a picture tube spark gap that arcs over causing the shutdown symptom. In the RCA TX82 chassis, a bright picture and chassis shutdown can be caused by shorted diode (DV52) in the beam limit circuit of transistor TV50.

The beam limit transistor (TV50) is located in the middle of the chassis, at an angle from the vertical output transistor mounted on a metal shield as heat sink. The 9V source is fed from the cathode of the 1N4148 diode. Replace diode DV52 with a manufacturer's exact replace-

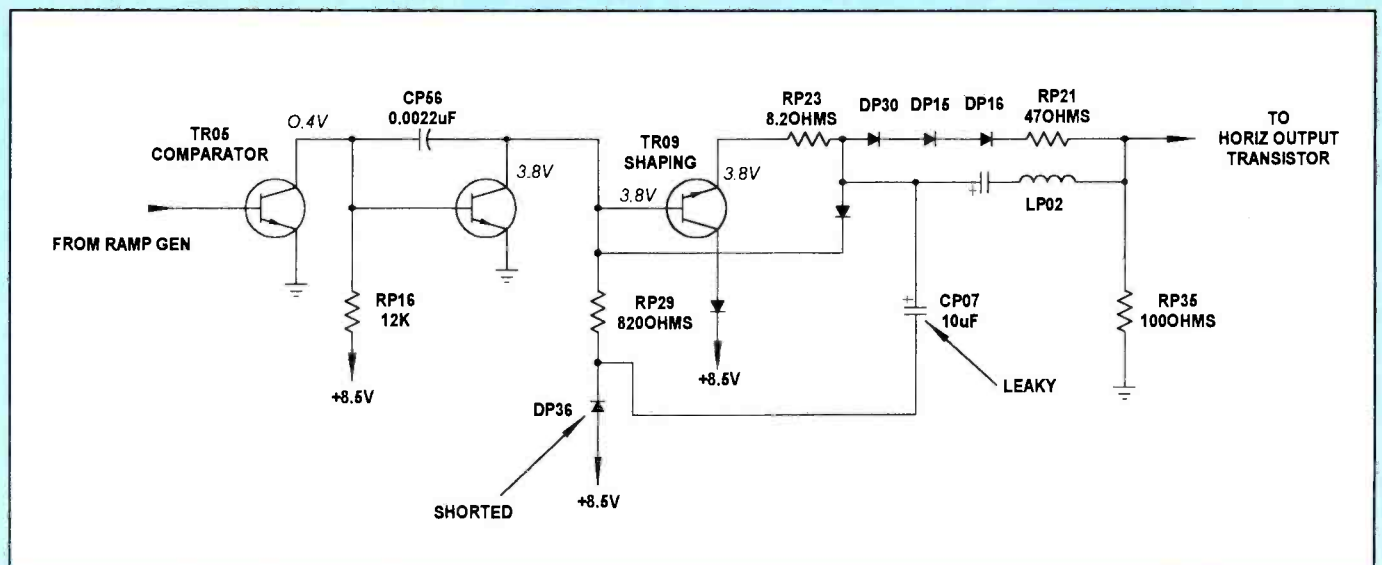

Figure 3. Replace leaky DP36 and CP07 located in the TP09 shaping circuits to restore a dead chassis to operation.

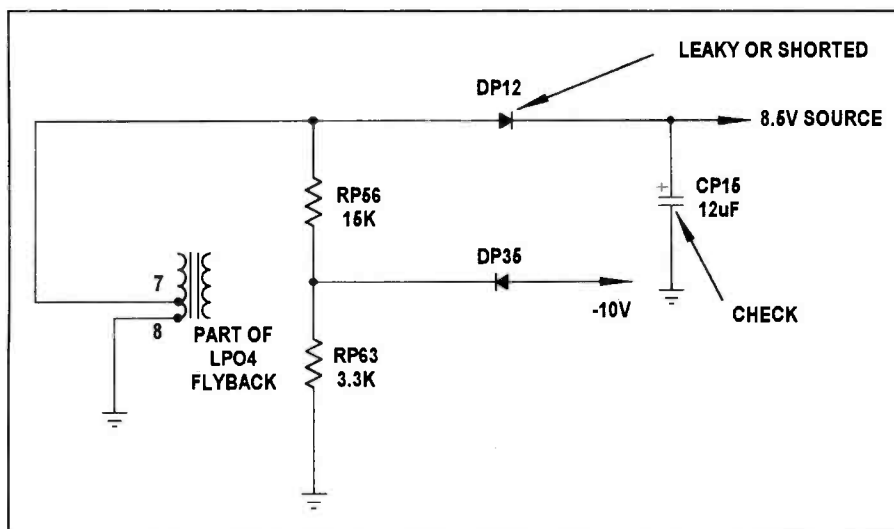

Figure 4. Check for a leaky DP12 and defective flyback transformer (LP04) when the horizontal output transistor (TP10) runs too hot.

ment, part number (198581), or a universal replacement.

Test the beam limit transistor TV50 in circuit, and check RV154 (133kΩ), and CV18 (10μF) electrolytic in the same circuit as well. Disconnect one end of RV54 resistor to be sure you get an accurate reading. Check the electrolytic capacitor CV18 in circuit with the ESR meter. If the reading is in the red or yellow area, replace it.

Another bright picture and shutdown symptom might be caused by a defective scan rectifier diode, DP19, in the 150V source. DP19 provides a 150V source to the red, green, and blue driver transistors and picture tube elements. Suspect DP19, RP55, and CP22 if the chassis has a extremely bright picture with retrace lines and then shuts down. A shorted diode DP19 can destroy or open RP55 (10Ω) in the 150V source (Figure 6).

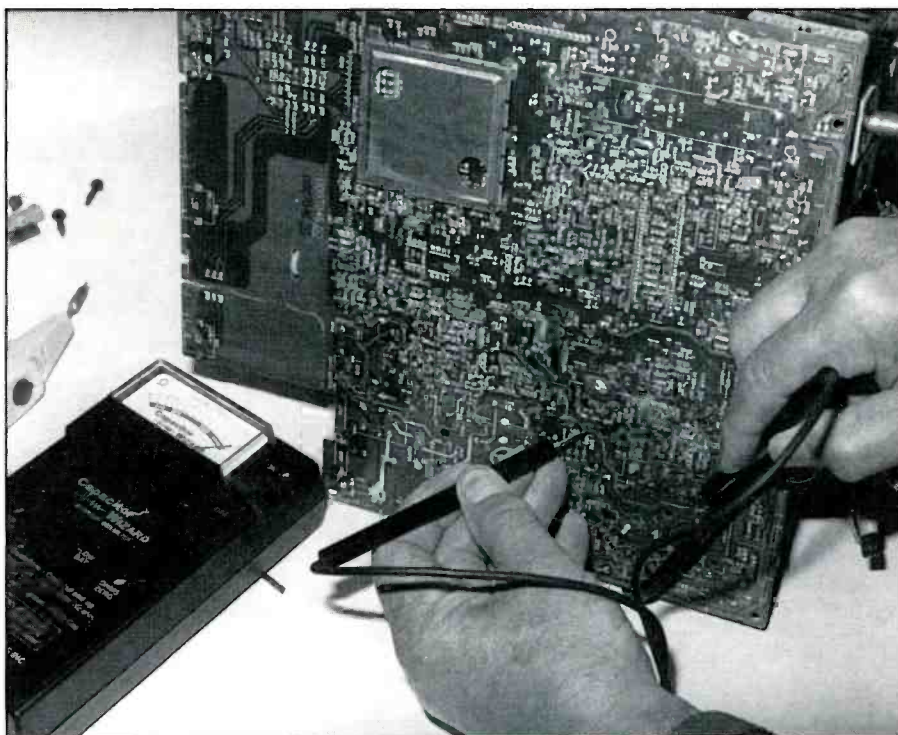

Figure 5. Check electrolytic capacitors in the circuit with an ESR meter.

Check CP22 with a capacitor tester or the ESR meter. DP19 can also produce an intermittent shutdown symptom.

A burned or open DP18 and open RP68 (0.68Ω) resistor in the 12V source can cause the set to pulse off and on. The 12V source provides supply voltage for the TV processor (IL01). IC IL01 develops the horizontal and vertical drive pulse for the vertical and horizontal sweep circuits. Replace both components to prevent future service problems in the secondary low voltage circuits.

Vertical problems

Insufficient or intermittent vertical sweep can be caused by TV processor IL01. If you encounter one of these sets that either is intermittent or has no vertical sweep, scope the output pin 18 of IC IL01 and pin 2 of IF01. Monitor the supply voltage pins 11 and 45 of the TV processor IC. If the voltage at either or both of these pins is low, suspect a defective IC. In a some cases in which this IC has caused intermittent vertical problems, the voltages at pins 11 and 45 were within specification. If you encounter a set that is either intermittent or exhibits no vertical sweep, and you have no other explanation for this symptom, replace IL01 with an exact replacement, part number 210543, even if the voltage at pin 11 appears to be in specification.

TV processor IL01 is mounted directly behind the tuner assembly and is in a spot that makes it difficult to remove (Figure 7). The chassis should be completely pulled from the cabinet to remove the TV processor. Do not mistake the system control IC (IR01) for the TV processor, which is located inside a metal shielded area.

After all 44 terminals are unsoldered and the processor removed from the board, replace it with an exact replacement device, part number 210543. Double check all pin connections for a good soldered joint. You can use the ESR meter to check each pin terminal at the IC pin where the first component connects on the PC wiring. This ESR meter can quickly point out a bad soldered connection.

Besides replacing the TV processor to correct a vertical problem, check the terminal connections of the components

in the vicinity of pin 17. Inspect the terminal connections of RF03, RF04, RF05, and CF02 when there is no vertical sweep. Remove one end of each resistor and test for accurate resistance with a good ohmmeter. Test CF02 (4.7 μ F) electrolytic with the capacitor tester or ESR meter.

If you observe a vertical sweep waveform at pin 18 of the TV processor, but the vertical sweep is either improper or absent, check out vertical output IC (IF01), capacitor CF09 (100 μ F), diode DF04, and the 22V supply voltage. If the vertical output waveform is fairly normal at pin 2 of vertical output IC, suspect CF01 (1000 μ F), RF01 (2.7 Ω) or an open vertical winding of deflection yoke DY1.

System control circuit problems

System control circuits in many modern TV sets.

- Objectionable noise caused by these circuits can include a chirping sound at turn-off, motorboating audio, and some audio hum in the speaker.

- A defective standby switch transistor can cause a dead chassis.

- Intermittent shutdown caused by a defective diode can result in a dead chassis.

- Intermittent shutdown by diodes in the system control circuits can cause motorboating in the sound.

All of these symptoms can be caused by a defective component in the system control circuits.

If the set is dead, go directly to the standby switch transistor (TP12) and on/off switch (TP11). If you hear a chirping sound as the set is turned off, replace the on/off transistor. Replace shorted TP11 with the original part number 198751 or with a universal replacement. Open TP12 can be replaced with the original replacement 198752 (Figure 8).

Intermittent shutdown and a motorboating sound might result in a defective diode in the Error Amp and Power Kill circuits of the system control circuits. Automatically replace DP01 when the chassis operates intermittently and you can hear a motorboating sound in the speaker. At the same time, check RP01 (8.2k Ω resistor, standby switch transistor (TP12), and on/off switch transistor (TP11) for open and shorted conditions.

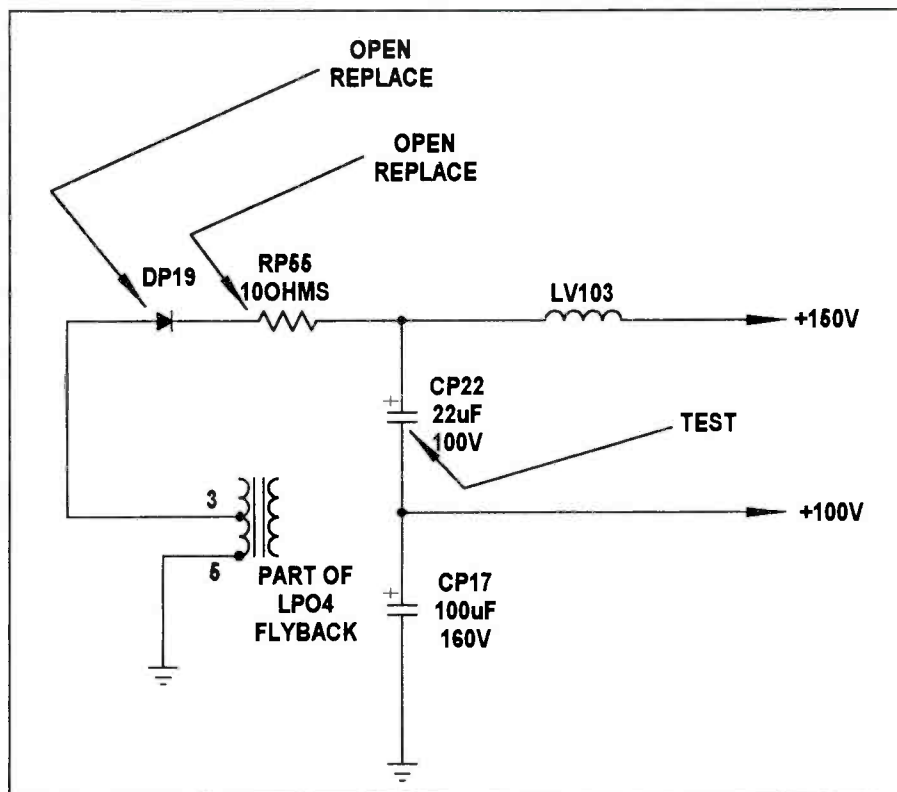
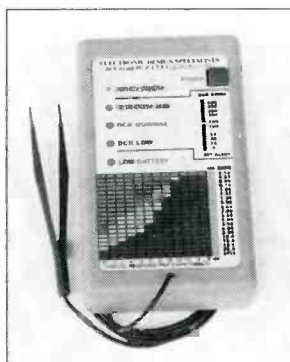

Figure 6. If the symptom is excessive brightness followed by shutdown, replace DP09 and RP55.

Don't be stupid.



www.eds-inc.com

Smart techs know that to be productive you need to find defective components quickly. Maybe that's why 37 TV stations, General Motors, Matsushita Industrial, Sears Service, Pioneer Electronics, Panasonic Authorized Service, and thousands more independent service technicians have chosen the **CapAnalyzer 88** over all of the other capacitor checkers. Check www.eds-inc.com/88users.html for actual **CapAnalyzer** users' comments as they compare their **CapAnalyzer** to the "wizards" and "z-meters" they already own. They all prefer the **CapAnalyzer 88** because it does what you expect it to do: check electrolytic capacitors, in-circuit, with 100% accuracy. Period. No unsoldering to check out-of-circuit, no mistaking a shorted or leaky cap as good, as other "ESR" meters do, no guessing about whether a value is good or bad. With our exclusive three-color chart right on the front panel, auto-discharge, multi-beep alert, and one-handed tweezer test probe, even your pet monkey could find defective caps in that problem TV, monitor or VCR in a few seconds. 55% of sales of **CapAnalyzers** are from recommendations by other **CapAnalyzer** owners, and 9% of sales are from previous customers buying a second unit. So get smart and buy one for yourself. It's only \$179. With our exclusive 60-day satisfaction-or-money-back guarantee, you risk nothing. Your only problem will be running out of work as you take care of all of those "dogs" that you've been sitting on. We're EDS. We make test equipment designed to make you money. Available at your distributor now. **561-487-6103**

What's Your Best Servicing Value? The magazine that makes money for you!

THE PROFESSIONAL MAGAZINE FOR ELECTRONICS AND COMPUTER SERVICING
ELECTRONIC

Servicing & Technology

As an electronic servicing professional, it's crucial for you to keep current in an industry that's always growing and changing.

Each month, **ES&T** brings you how-to service articles on TVs...VCRs... Computers... CD players...Microwave ovens...Audio products and more. It's the information you need to do your job every day.

Regular columns and special features from experts will make you more efficient - and more profitable - in no time. Plus, our monthly PROFAX, a FREE 8-page pull-out of popular TV, VCR and computer schematics, makes **ES&T** an even greater value.

SUBSCRIBE TODAY!!

United States	
1-yr (12 issues).....	\$26.95
2-years (24 issues).....	\$49.95
Canada/Mexico	
1-yr (12 issues).....	\$36.95
2-years (24 issues).....	\$69.95
Foreign Air Post	
1-yr (12 issues).....	\$44.95
2-years (24 issues).....	\$85.95

When ordering include: Name, address, city, state, zip. Check money order, MasterCard, VISA, Discover, and American Express accepted. Send credit card number along with expiration date. If renewing, send a label along with your request.

Send all Subscription requests to:
Electronic Servicing & Technology
25 Newbridge Road, Hicksville, NY 11801
Ph: 516-681-2922 FAX: 516-681-2926

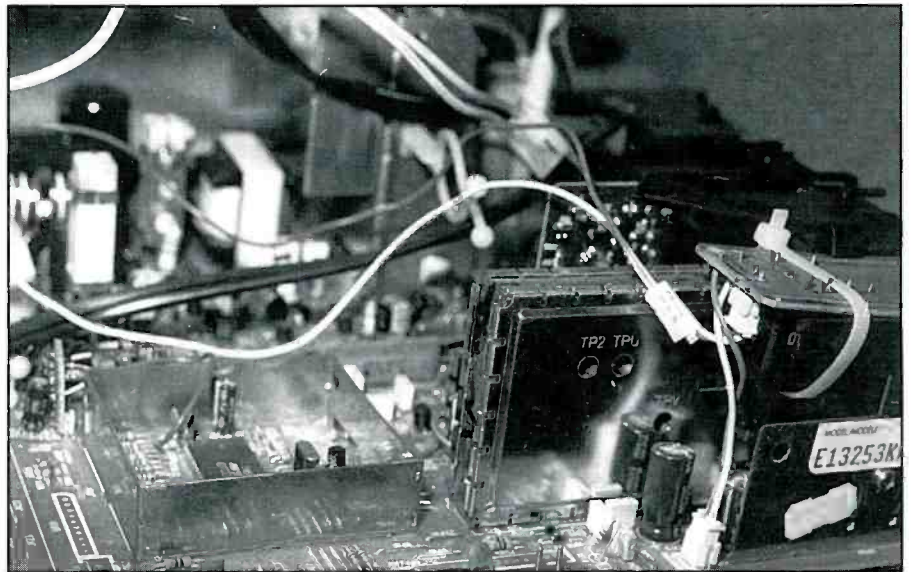

Figure 7. When you encounter one of these sets with the symptom of intermittent vertical, or a complete absence of vertical sweep, replace TV IC Processor (IL01).

Replace DP01 with the original part number 198589 or universal replacements ECG519 or RCA SK3100.

Conclusion

Most of the problems that you'll encounter in the RCA TX82 and TX81 chassis are in the secondary low voltage sources. Case history symptoms should

be recorded in a card file, computer, or circled upon the schematic diagram. These case histories are valuable service information that can quickly locate troubles in the TV chassis and are at your fingertips for future reference. It just takes a few minutes to record and save a case history that you may subsequently encounter in every similar chassis. ■

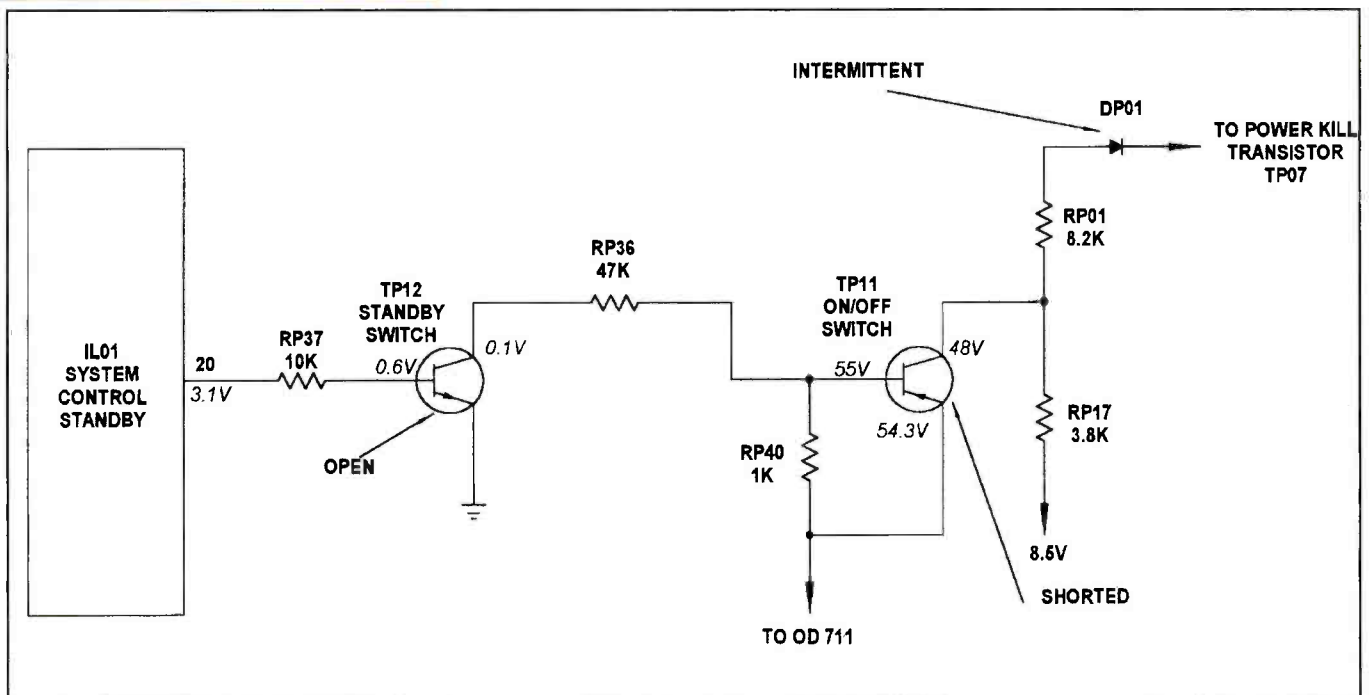

Figure 8. An open standby switch transistor (TP12), shorted on/off transistor (TP11), or intermittent DP01 in the system control circuits can cause noise, or a dead set.

Products

Fume extraction

Airidus' Stainless Steel Flexi-Arm removes annoying and toxic soldering fumes from solder pots, hotplates, dispensing/adhesive applications, and other localized soldering or assembly processes. Space-saving, flexible, and 4" long, this high volume fume extraction accessory comes complete with a "through-bench" mounting flange and can be positioned as the worker requires. A range of push-fit nozzles are available to meet individual applications.



The unit's integral balance valve ensures even, steady performance, and its robust design ensures long life and reliability, says the manufacturer. Additionally, it is ESD safe and equipped with a grounding cord.

Airidus, 1530 O'Brien Drive, Menlo Park, CA 94025,
Phone: 888-853-7960, Fax: 650-325-5932

Circle (72) on Reply Card

Mini multimeter

BK Precision announces the Model 2408 Mini-Pro DMM. The lightweight, portable digital multimeter also features a non-contact voltage indicator.

The built-in non-contact voltage indicator eliminates the need for a separate voltage indicator pen. The 2408 measures ac voltages from 70V to 480V @ 50 Hz to 60 Hz and provides both an audible "buzz" and a flashing indicator light when placed in close proximity to a power source.



Other features include measurement of voltage to 600V and current to 10A, resistance to 20MΩ, as well as diode test, continuity test, data hold, a 200 count LCD, low battery indicator, and auto zeroing.

BK Precision, 1031 Segovia Circle, Placentia, CA 92870-7137,
Phone: 714-237-9220, Fax: 714-237-9214, Website: www.bkprecision.com

Circle (73) on Reply Card

Microscope light

The Waldmann Scope offers a long working distance and large field-of-view. A scope "arm assembly" is also offered to replace virtually any existing boom stand.

The product is useful for detailed, close-up applications, including all types of assembly and inspection tasks, such as surface mount devices and wire bond. Two light sources are offered; dual 5W halogen lamps, attached to the arm assembly, offer crisp point source illumination directly to the work area.

Or, a fluorescent ring microscope illuminator which offers a 5,000 hour lamp life and fixed even illumination is available.

The microscope features a working distance of 225mm (8-6/7") and a magnification range from 3.5x to 30x using optional eyepieces ranging from 10x to 30x and the .7x supplemental lens. This produces high resolution images and excellent stereoscopic effect. The standard 8.5" focal length can be increased to 12" with the optional .7x supplemental lens. In addition, the field-of-view (46mm at 5x) can be increased to 68mm at 3.5x with the optional .7x supplemental lens.



Waldmann Lighting, 9 West Century Drive, Wheeling, IL 60090,
Phone: 800-634-0007, Fax: 847-520-1730, Website: www.waldmannlighting.com,
E-mail: waldmann@enteract.com

Circle (74) on Reply Card

DMMs

The MX Series DMMs from AEMC display up to 50,000 counts. They offer true RMS performance (ac or ac+dc) for applications where accuracy is required for non-sinusoidal wave shapes. Features include separate battery compartments, leads that won't accidentally be disconnected, 600V fuses, metal oxide varistors, sealed and waterproof cases. The meters perform the dB or power calculation, and offer ultra-high input impedance which is selectable to 1GΩ on the 500mV range.



AEMC Instruments, 99 Chauncy Street, Boston, MA 02111, Phone: 617-451-0227,
Fax: 617-423-2952, Website: www.aemc.com

Circle (75) on Reply Card

Portable IC testers

BK Precision announces the addition of two new handheld, battery-powered Integrated Circuit (IC) test units. Both models (the Model 570 for linear ICs and the Model 575 40-pin Digital IC Tester) have extensive built-in libraries. The new testers are for use by service technicians in the field or lab to identify or test any particular IC that is listed in the unit's integrated test library. Both units provide pin-out information of the tested ICs.

The Model 570 Linear IC Tester is compact and battery-powered for portability in the field or lab. The user plugs in the IC, keys in its part number or uses the Auto Detect feature, and the Model 570 completes the test. The unit tests all common analog ICs from op-amps to special function devices. Proven test software using advanced technology makes the Model 570 an ideal addition to any technician's tool box.

BK Precision, 1031 Segovia Circle, Placentia, CA 92870-7137,
Phone: 714-237-9220, Fax: 714-237-9214, Website: www.bkprecision.com

Circle (76) on Reply Card

Digital versatile disk technologies: Versatility, capacity, and growing popularity

by John A. Ross

In the October 1999 issue of **ES&T**, we took a close look at the assemblies and circuits that allow CD-ROM and DVD players to function. Within that article, we discussed the physical construction of the discs, the information encoding process, and the use of Dolby AC-3 audio and MPEG-2 video programming. The article also covered the application of electronic systems such as digital signal processors, optical pick-up units, microcontrollers, and audio-video decoders.

In this article, we'll go further with our definition of the technologies that allow DVD players to function. Moreover, we'll also discuss the future potential for DVD technologies as well as the options given by those technologies. As always, we'll also consider more techniques for servicing and maintaining DVD players.

Defining the technology

In the October article, I consistently referred to DVD technology as digital video disc technology. Lately, however, the DVD has begun to represent digital versatile disc technologies because of the potential applications found with the storage medium. Going back for a brief review, the versatility stems from the use of digital rather than analog formats for encoding and decoding information; the capability to store large amounts of information on a single disc; and the interactivity found through the technology.

From all this, we can break DVD technologies into separate categories. DVD-video covers the disc technologies that play full-length movies and interface with a television. A close cousin — DVD audio — reproduces studio quality

Ross is a technical writer and microcomputer consultant for Ft. Hays State University, Hays, KS.

Table 1 — Comparison of DVD Standards

DVD Standard	Disc Size	Layers	Data Storage Capacity	Video Storage Capacity
*(2 gigabytes = 1 hour of video)				
DVD-1	3.1 inches	Single Side/Single Layer	1.4 Gigabytes	0.5 hours
DVD-2	3.1 inches	Single Side/Dual Layer	2.7 Gigabytes	1.3 hours
DVD-3	3.1 inches	Double Side/Single Layer	2.9 Gigabytes	1.4 hours
DVD-4	3.1 inches	Double Side/Dual Layer	5.3 Gigabytes	2.5 hours
DVD-5	4.7 inches	Single Side/Single Layer	4.7 Gigabytes	2 hours
DVD-9	4.7 inches	Single Side/Double Layer	8.5 Gigabytes	4.5 hours
DVD-10	4.7 inches	Double Side/Single Layer	12.33 Gigabytes	6.5 hours
DVD-14	4.7 inches	Double Side/Single Layer on One Side and Dual Layer on Other Side	13.24 Gigabytes	6.5 hours
DVD-18	4.7 inches	Double Side/Dual Layer	17 Gigabytes	8 hours
DVD-R	3.1 inches	Single Side/Single Layer	3.68 Gigabytes	n/a
DVD-R	3.1 inches	Double Side/Dual Layer	7.38 Gigabytes	n/a
DVD-R	3.1 inches	Single Side/Single Layer	1.23 Gigabytes	n/a
DVD-R	3.1 inches	Double Side/Dual Layer	2.46 Gigabytes	n/a
DVD-RAM	4.7 inches	Single Side/Single Layer	2.58 Gigabytes	n/a
DVD-RAM	4.7 inches	Double Side/Single Layer	5.16 Gigabytes	n/a

audio and works like the common compact disc audio systems that have become widely popular. While DVD-ROM describes the read-only disc that functions with a computer system, DVD-RAM is a writeable version of the same technology. As mentioned in October, each of the disc categories can hold many times more data than standard compact discs along with interactivity and high quality.

DVD layering

Digital Versatile Discs may arrive as single-layer, dual-layer, or quad-layer discs that can hold as much as 18 gigabytes of data. The creation of a single-sided, dual-layer disc occurs through the placement of one data layer on each sub-

strate and then gluing the halves together with transparent adhesive. As a result, the laser located in the optical pickup unit can read both layers from one side. However, recent advances in DVD technology have begun to change the production process.

Because the new DVD-18 standard uses a double-side/dual layer approach that provides four data layers, it requires a different process. With four data layers, each substrate must support two layers. As a result, the process requires the stamping of a second data layer on top of the first. Given the complexity of this process, the DVD-18 discs will have a greater cost and a slower entrance into the market.

Using the dual-layer disc depicted in Figure 3 as an example, the laser from

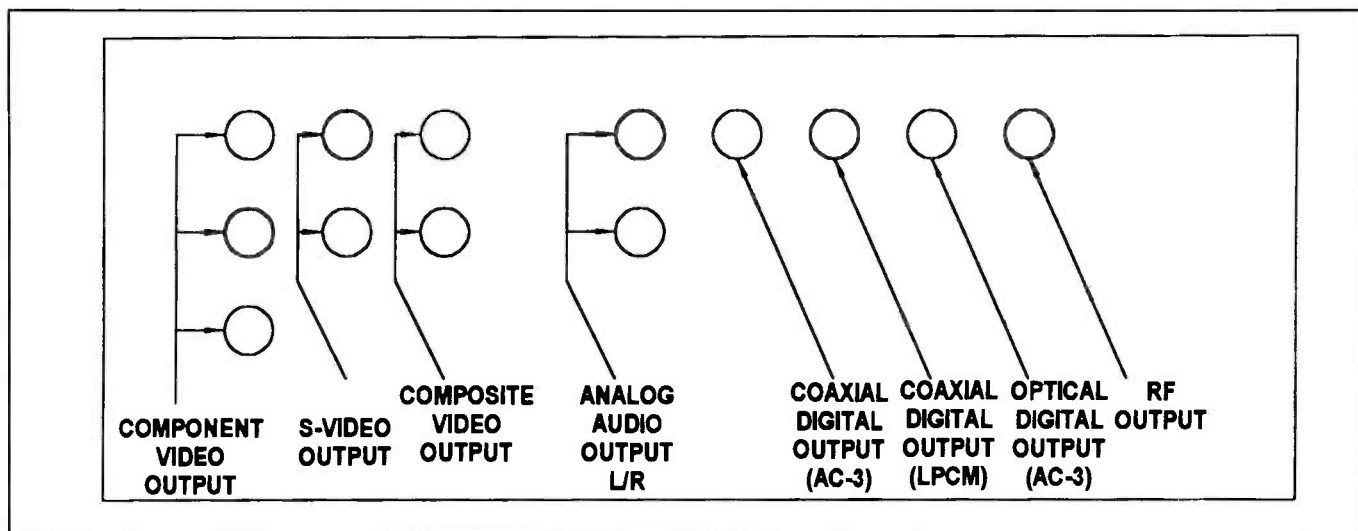

Figure 1. Using the dual-layer disc depicted here as an example, the laser from the optical pick-up unit can see through one layer of semi-transparent data and read the second layer of data.

the optical pick-up unit can see through one layer of semi-transparent data and read the second layer of data. With both layers found on the same side of the disc, a dual-layer DVD-Video disk can contain over four hours of high-quality video programming.

Depending on the manufacturer, the second layer may feature either a parallel track path (PTP) layout that allows both tracks to run in parallel or an opposite track path (OTP) layout where the second track runs in an opposite spiral when compared to the first. The use of the PTP layout allows the application of independent data or special switching effects. With the OTP layout, the pickup unit reads out from the center of the first track and in from the outside on the second track. Opposite track path layout allows the playback of continuous video across both layers in a dual-layer disc.

Changing from one layer to another with the OTP layout may cause the video to freeze for less than one-half of a second. In electronic terms, this may seem as a long amount of time. However, few customers will notice the momentary freeze. While the manufacturing process of the disc affects the freeze time, the design of the player also has some effect. All in all, the use of the OTP layout provides higher data rates for long movies and, as a result, higher quality playback.

DVD capacity

Because of the need to read through one layer to see the data in the second

layer, dual-layer discs do not completely double the capacity of single-layer discs. Several reasons for this small decrease in capacity exist. Reading through the layer also increases the chances for interlayer crosstalk. To decrease those chances, manufacturers have slightly increased the minimum pit length in both layers and the reference scanning velocity. The longer pits combine with longer spaces and provide easier reading and less jitter. However, increasing the length of the pits also results in fewer pits per revolution and the subsequent reduction in capacity.

Table 1 compares the disc sizes, layer formats, data storage capacity in gigabytes, and video storage capacity in hours for all DVD standards. As the table shows, a disc can be single-sided or double-sided, and each side can have one or two layers of data. The amount of video stored on the disc depends on the amount of accompanying audio and the compression ratio for the audio and video information.

As the table shows, a single-layer DVD stores two hours of video. While the table compares storage capacity, it does not show the effect of bit rates on the carrying capacity of the disc. When we consider bit rates, video requires 3.5 Mbps (million bits per second) while three soundtracks require 1.2 Mbps. On the average, a two-hour movie with three soundtracks requires a minimum of 5.2 Mbps. A dual-layer disc can hold a two-hour movie at an average of 9.5 Mbps. If we place mostly audio informa-

tion on the same disc, we find that the disc can play for nearly 24 hours. If the audio information is compressed at a rate of 64 kbps and is monophonic, the dual-layer disc can play for 295 hours.

DVD-Video

Depending on the number of layers found on the disc, DVD-Video provides the capability to reproduce two to eight hours of high-quality digital video programming on a single disc. The standard also supports widescreen movies and holds up to eight tracks of digital audio that contain as many as eight channels. With this, DVD-Video allows the optional branching of video so a particular disc may include several story lines or ratings. The interactivity included with DVD-Video also may allow the use of menus and even add-ons such as games or quizzes. Digital encoding and large storage capability also combine to provide a video medium where the customer may also have the option to select up to nine different camera angles during playback. However, the addition of one camera angle for a program roughly doubles the amount of space needed and decreases the playing time by one-half.

Standard features for DVD-Video discs include language choices for the movie title and listing of credits. Depending on the disc producer, the language feature may also cover the selection of video scenes, audio tracks, or special effects menus. As with VCRs, DVD-Video players and discs combine to provide special effects capabilities

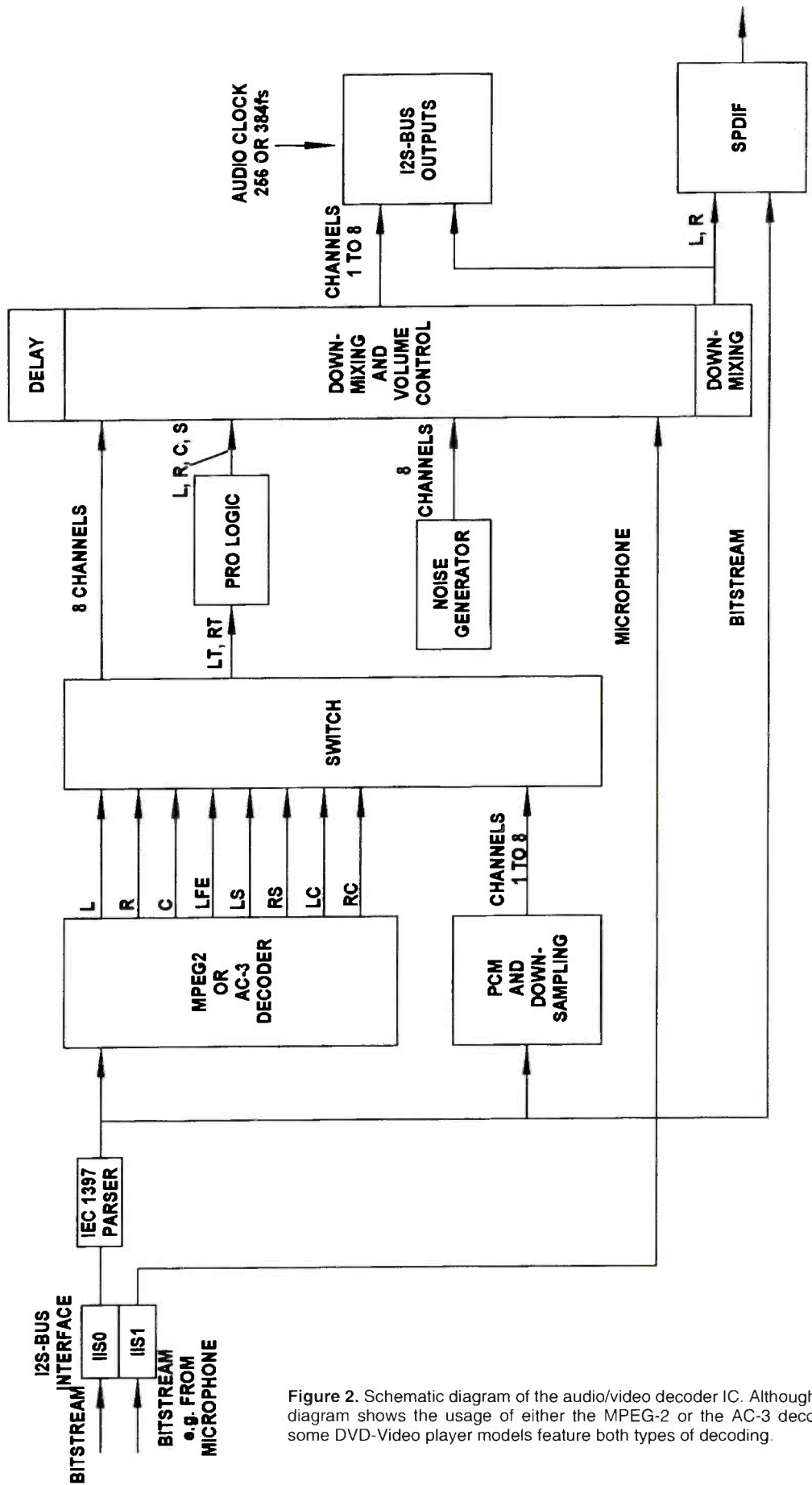

Figure 2. Schematic diagram of the audio/video decoder IC. Although the diagram shows the usage of either the MPEG-2 or the AC-3 decoder, some DVD-Video player models feature both types of decoding.

such as freeze, step, slow, fast, scan, random play, repeat play, search to a specific track, and the playback of selected sections. In some cases, other encoded content on the disc supports a function, such as parental control, while, in other instances, the circuitry in the player provides the functionality. Table 2 lists common features often found with DVD players.

Audio playback with DVD-Video

Regardless of the manufacturer, all DVD players utilize either a Dolby AC-3 or MPEG audio decoder that functions as part of the larger audio/video decoder IC seen in the October 1999 article. Figure 2 repeats the schematic diagram of the IC as shown in the previous article. Although the diagram shows the usage of either the MPEG-2 or the AC-3 decoder, some DVD-Video player models feature both types of decoding.

An audio decoder translates the multi-channel audio given by the programming into pulse-code modulated audio. From there, the PCM audio feeds into the digital output and becomes converted to a standard analog audio output signal. While most DVD players utilize a two-channel-output decoder, some have as many as six channels of audio output.

DVD-Video produces studio-quality audio playback through pulse-code modulation of the digital audio output and through the Dolby AC-3 or MPEG-2 audio encoding/decoding schemes. While DVD-Video players offer compatibility with audio CDs, the use of pulse-code modulation provides higher sampling sizes and rates than those seen with standard audio CDs. The compression format seen with Dolby AC-3 allows the storing of movie soundtracks as discrete, multi-channel surround sound. The combination of precise processing and encoding allows the consumer to experience the same audio quality as that heard in theaters.

Nearly all manufacturers include digital audio outputs with DVD-Video players. Moving to the rough sketch of a DVD-Video player rear panel shown in Figure 3, the digital audio outputs carry the Dolby AC-3 format as well as PCM and MPEG-2 audio signals. No across-the-board voltage and setup exists with DVD players. Most players rely on the

SMPTE 253M standard with a 286mV sync, a zero percent luma setup with 700mV peak, and a +/-300mV color excursion. However, some may use the Betacam standard with a 286mV sync, a 7.5% luma setup with 714mV peak, and a +/-350mV color excursion while others will use the M-II standard with a 300mV sync, a 7.5% luma setup with 700mV peak, and a +/-324.5mV color excursion.

The coaxial and optical connectors allow the connection of either a 75Ω coaxial cable or a fiber optic cable between the player and the receiver. The high quality cables ensure the maximum transfer of the audio signals. In turn, a receiver connected to the digital outputs must have the capability to decode the digitized audio signals.

Depending on the cost of the player, additional connections also may exist. Some players feature individual connectors for interlaced analog video as well as progressive analog video. Others may have six RCA jacks for the analog surround sound output and an AC-3 RF output for laserdisc output. The RF output shown in the diagram allows the connection of the player to a television and playback through either channel three or four.

Many options

As the diagram indicates, most DVD players provide several options for the video and audio connections. In effect, the manufacturers have provided the options to best match the capabilities of the consumer's existing video and audio systems. If the consumer's DVD player and television support progressive scanning, the attachment of high-quality cables between the three progressive video output jacks on the player and the three progressive input jacks on the television will provide the best possible reproduction of the video programming. Progressive video provides a flicker-free image with superb vertical resolution and smooth motion.

In addition to progressive video, the manufacturers also provide the component video option seen in the figure. This option allows the player to output an interlaced video signal through 3 RCA jacks, BNC connectors, or a 20-pin SCART connector. Cables connect from the video output connectors of the player to the video inputs of the television.

Although the progressive and interlaced formats provide the best viewing options, manufacturers also provide S-video and composite video outputs. The four-pin S-video connects directly from the player to an A/V receiver that can switch S-video. Standard RCA jacks allow the transfer of composite video signals from the player through standard video cables to the receiver. Even though an RF video output offers a degraded signal in terms of DVD quality, many players retain the RF connection so that a coaxial cable can connect from the player to a television. Manufacturers advise against connecting the video from the DVD player through a VCR because of the Macrovision protection used on the discs. The protection will cause repeated lightening and darkening of the picture when played through a VCR.

All DVD-Video players include analog audio output connections in the form of RCA jacks for stereo/surround sound. Any disc that includes AC-3 or MPEG-2 audio information will automatically decode and mix the information at the digital output for connection to the receiver. The RF output jacks allow the output of AC-3 RF output from laser discs.

Pulse-code modulation

Pulse code modulation is a sampling technique for digitizing analog signals and works especially well for transmitting analog full-motion video, telemetry, and audio signals. The PCM scheme samples a signal 8000 times a second and represents each sample with 8 bits for a total of 64Kbps. Signals in the PCM scheme have a binary format.

Obtaining PCM from an analog waveform at the source of a communications circuit occurs through the sampling of the analog signal amplitude at regular time intervals. The number of samples per second is several times the maximum frequency of the analog waveform in hertz. Quantization rounds off the instantaneous amplitude of the analog signal at each sampling to the nearest of several specific, predetermined levels. The number of levels is always a power of 2; for example, 8, 16, 32, or 64; that can be represented by three, four, five, or six bits, respectively.

As a result, the output of a pulse code modulator occurs as a series of binary numbers. Each of these binary numbers is represented by some power of 2 bits. At the receiver, a pulse code demodulator converts the binary numbers back into pulses having the same quantum levels as those in the modulator. These pulses are further processed to restore the original analog waveform.

Interactive features

DVD-Video players and the software found on the discs support a command set that supports a few basic interactive features such as menus, parental control selections, title and sub-title selections, and the selection of different camera angles. The menu functions give the customer the ability to choose content and features. Most menus consist of a graphic display that, in turn, contains up to 36 selectable buttons. As with other consumer electronic products, the menus combine with the multi-key capability of remote controls.

The use of a digital signal processor within the DVD player allows the implementation of additional command sets that include simple math, logic operations, comparisons, and the manipulation of data found in registers. Each processor contains 24 system registers that hold language codes, audio settings, sub-picture settings, parental control settings, and other system-level data. In addition, the DSP also contains 16 general registers that store command information. The commands used within the processor allow branching between command sets, the control of player settings, and allow the interfacing between the customer and the unit. In some cases, this interfacing may include the selection of different camera angles or the jumping from one area of the disc to another.

Branching from one area of content to another occurs through the use of program chains. The content found on a DVD-Video disc breaks into the titles of movies or albums and parts of titles that correspond with chapters or songs. Titles consist of cells linked together by different types of program chains. The types are sequential play, random repeat or play, or random order with no repeats. Options such as additional camera angles, parental control, and seamless branching become possible because

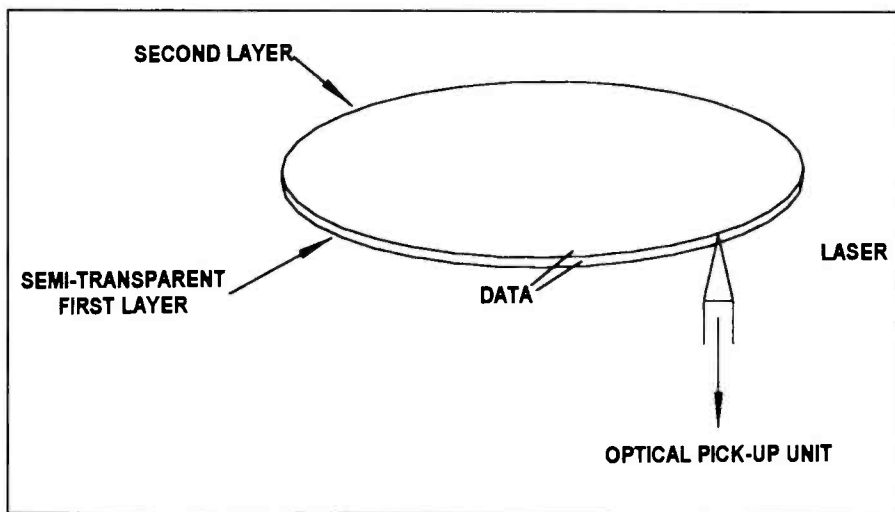

Figure 3. DVD-Video player rear panel.

more than one program chain can use individual cells. As a result of this interleaving, different program chains can define different individual sequences found in the same material.

A technical perspective on DVD-Video

The manufacture of a DVD-Video disc involves the encoding of programming information from digital studio master tapes to the MPEG-2 format. Because the MPEG-2 encoding is a lossy scheme, the encoding and compression process removes any information that consistently repeats within the movie or information that remains imperceptible to human eyes. As a result, the encoded and compressed video may contain flaws called artifacts, or pieces of signal that were not in the original video. Most manufacturers utilize a higher compression data rate in the range of 6Mbps so that the reproduced movie has consistently higher quality.

Since Japanese companies manufacture most DVD players, the black-level set-up may have a value of zero IRE instead of the 7.5 IRE recognized as a standard in the United States. Because of this, televisions connected to a DVD-Video player require adjustments to prevent the blurring of dark scenes. IRE units are a linear scale for measuring the relative amplitudes of the components of a television signal with a zero reference at the blanking level. In the NTSC system, the tip of horizontal sync is located at -40 IRE while the reference white is

found at 100 IRE and the $1V_{pp}$ video signal is equal to 140 IRE units.

DVD technologies can provide picture resolutions at a maximum of 720 x 480 at 29.97 frames/sec or 720 x 576 at 25 frames/sec. The players sub-sample the pictures at 4:2:2 down to 4:2:0 and allocate an average of 12 bits/pixel in an analog format. When considering lines of horizontal resolution, a DVD could produce 540 lines on a standard television and 405 lines on a widescreen television. Filtering decreases the number of lines to 500 for a standard television. In comparison, the VHS format used for VCRs provides 230 lines of horizontal resolution.

Again considering the capacity of the disc, a DVD can have a maximum of 32 sub-picture streams that overlay the video for subtitles, closed captioning, captions for children, and menus. Closed caption text stores in the video stream as MPEG-2 user data. The player regenerates the text as a line-21 analog waveform in the video signal for decoding by the closed caption decoder found in the television. The sub-picture streams are full-screen, run-length-encoded bitmaps that remain limited to four pixel types. Each group of sub-picture streams may select four colors from a palette of 16 colors. Display command sequences embedded in the sub-picture streams allow the creation of scroll, move, color, and fade effects.

DVD-Video, NTSC, and PAL

One of the dilemmas faced by DVD manufacturers is compatibility with dif-

Table 2 — DVD Player Features

Analog composite or RGB video output
Progressive-scan analog composite or RGB output
Six-channel analog output from internal audio decoder.
Recognition and output of Digital Surround audio tracks.
Compatibility with video compact discs.
Playback
Forward and Reverse Scan
Freeze
Slow
Fast
Random play
Repeat play
Search to a specific track
Reverse single frame stepping.
RF output
Multilingual on-screen display
2x or 4x digital zoom

ferent video broadcast standards. As you know, the NTSC format has 525 scanning lines at 60Hz and 29.97 interlaced frames per second. The PAL standard has 625 scanning lines at 50Hz and 25 interlaced frames per second. All this translates into a difference in picture size and pixel aspect ratio (720x480 vs. 720x576) as well as a difference in display rate. To further complicate the dilemma, film has a coded frame rate of 24 progressive frames per second.

DVD technologies rely on MPEG-2 encoding and decoding to ensure the high quality reproduction of movies and other video programming. Each disc contains one track of MPEG-2 compressed digital video either in the constant bit rate or variable bit rate format. Because the encoding process relies on a 24 frame per second progressive source from the original film, the MPEG-2 encoder embeds flags into the video stream to ensure compatibility with either 60Hz or 50Hz video standards.

A DVD manufacturer has the capability to include additional video and audio so that the disc will play in either a NTSC or PAL standard player. As we saw with the interactive features, however, including additional video or audio information decreases the amount of available space for the playback of the desired programming. In almost all cases, the MPEG-2 video is stored in either the NTSC or PAL format.

Players using the PAL/SECAM standard can play NTSC formatted discs as well as PAL formatted discs. To accomplish this compatibility, the player partially converts the NTSC signal to a 60Hz PAL signal. The player uses the PAL 4.43 color encoding format at a 60Hz scanning rate with 525 lines. Modern PAL standard televisions can reproduce a picture given through this type of signal. With all this, an NTSC formatted disc will play in a PAL standard player while a PAL formatted disc will not play in an NTSC standard player.

DVD-Audio

Although DVD-Video products include the capability to produce high quality video, manufacturers have begun to produce DVD-Audio products that use a separate format. Much of the delay in producing the audio equivalent in a DVD format

has occurred because of the need to apply copy protection features to the audio information recorder on the disk. The DVD-Audio specification includes new formats and features that store the content in a separate DVD-Audio zone on the disc that remains unseen by DVD-Video players.

The copyright protection included with DVD audio involves the use of a system called a digital watermark. To apply the digital watermark, the manufacturer uses embedded signaling that establishes a digital signature. Optional encryption keys take the form of inaudible noise so that a player will recognize and refuse to play copied audio.

DVD and computers

All computer manufacturers offer systems that include DVD-ROM drives. As we've already seen, the DVD format offers greater capacity and multimedia capability.

A 1x DVD-ROM drive has a 90msec to 200 msec seek time and a 100msec to 250msec access time. Data transfers at rate of 1.321 megabytes per second with burst transfer rates that can exceed 12 megabytes per second.

When compared to CD-ROM drives, a 1x DVD-ROM drive has the same speed as a 9x CD-ROM drive. In terms of motor speed, a 1x DVD-ROM drive has the same spin rate as a 3x CD-ROM drive. However, DVD-ROM drives exhibit faster spin rates when reading CD-ROMs and achieve 12x performance.

Newer 2x DVD-ROM drives transfer data at a rate of 22.2 megabits per second and read CD-ROMs at 20x speeds. The faster 6x, 8x, and 10x DVD-ROM drives read CD-ROMs at 32x speed and provide the potential of transferring data at a rate of 55.4Mbps. Enlarging the memory cache in the DVD-ROM increases the capability of the drive to transfer data at a faster rate. The higher speeds apply to the transfer of data rather than the ability to reproduce a video image.

The speed ratings of CD-ROM and DVD-ROM drives depend on the method for reading the data. Constant linear velocity (CLV) drives spin the disc at a lower slower rate when reading data located near the outside of the disc. Tracks located near the edge of the disk have a greater physical surface than tracks located near the center of the disc. Faster drives rely on Constant angular velocity (CAV) which causes the rotational speed to remain constant and uses a buffer to compensate for differences in the data transfer speed. As opposed to CLV drives, CAV drives have the fastest speed when reading data at the outside edge of the disc. When manufacturers provide maximum speed ratings for drives, they quote the fastest rather than the average speeds.

Hardware and software considerations

When considering hardware issues and DVD-ROM drives, connectivity remains the same as seen with CD-ROM drives in that EIDE and SCSI-2 connections are supported. With EIDE, the data cable connected to the DVD-ROM drive attaches to an EIDE connector found on the motherboard of the computer. The SCSI-2 connection requires the installation of a SCSI card. As with CD-ROM drives, all DVD-ROM drives have audio connections for playing audio CDs.

Almost all DVD-ROM discs rely on the UDF Bridge format that combines the DVD MicroUDF and ISO 9660 file systems.



Your Ticket to **SUCCESS**

More than 40,000 technicians worldwide are Certified Electronics Technicians. ISCET offers Journeyman certification in Consumer Electronics, Industrial, Medical, Communications, Radar, Computer and Video. For more information, contact the International Society of Certified Electronics Technicians, 2708 West Berry Street, Fort Worth TX 76109; (817) 921-9101.

Name _____
Address _____
City _____
State _____ ZIP _____

- Send material about ISCET and becoming certified
- Send one "Study Guide for the Associate Level CET Test." Enclosed is \$14.95 (includes postage/handling). *TX residents — include 8.25% sales tax.*

ES&T

Circle (65) on Reply Card

ORGANIZE AND PROTECT YOUR COPIES OF

THE PROFESSIONAL MAGAZINE FOR ELECTRONICS AND COMPUTER SERVICING

ELECTRONIC

Servicing & Technology

Now there's an easy way to organize and keep copies of your favorite magazine readily available for future reference.

Designed exclusively for **Electronic Servicing & Technology** by Jesse Jones Industries, these custom-made titled cases and binders provide the luxury look that makes them attractive additions to your bookshelf, desk or any location in your home or office.

Each binder/case is covered durable leather-like material; title is hot stamped in gold.

Whether you choose cases or binders, you'll have a storage system that's durable and well organized to help protect your valuable copies from damage.

Quantity	Cases	Binders
One	\$ 8.95	\$11.25
Three	\$24.95	\$31.85
Six	\$45.95	\$60.75

Add \$1.50 per case/binder for postage and handling. Outside USA \$3.50 per case/binder. (U.S. funds only)

Credit cards accepted: AMEX, Visa, MC, Diners Club (Min. \$15) PA Residents add 7% sales tax Allow 4 to 6 weeks delivery

Electronic Servicing & Technology
Jesse Jones Industries, Dept. 95 EST
499 East Erie Ave., Phil., PA 19134
1-800-825-6690

Using this system, the DVD-ROM technology provides backward compatibility for systems originally designed to accommodate CD-ROMs. In terms of operating systems, Microsoft Windows 98 includes DirectShow 5.2, which provides standardized support for DVD-Video and MPEG-2 playback, while Windows 95 accepts the installation of DirectShow. Although the DirectShow software establishes a standardized framework for DVD playback, the computer system also requires a hardware or software decoder.

Windows NT supports the data applications of DVD-ROM drives but provides little support for DVD-Video. The advent of Windows 2000 provides the same drivers and software seen with Windows 98 along with the same capability to read the UDF Bridge format. Internet Explorer 5.0 also includes the latest version of Windows Media Player and allows scriptable DVD playback in an authored HTML page.

While versions 8.1 and above of the Macintosh operating system can read UDF discs, Apple QuickTime 4 provides some support for DVD-Video and MPEG-2. Macintosh G4 models arrive with either DVD-ROM or DVD-RAM drives as standard equipment. In addition, some iMac, PowerBook, and G3 computers include DVD-ROM drives and hardware decoders as an option

Hardware and software decoders

If a consumer has the desire to play DVD-Video through their computer, several key points must be covered. First, the computer operating system or playback software must support regional codes and include the licensing to descramble copy-protected movies. Second, the computer must support Macrovision for the playback of copy-protected movies. Third, the system must also have a high-quality video adapter or accelerator and a television video output port. Along with those items, the system may also require software that reads the MicroUDF file format seen with DVDs. The software applications emulate DVD players and provide features such as menus, remote control, title lists, and sub-pictures.

Along with the DVD-ROM drive and the software support, the system must also include either hardware or software

decoding for the MPEG-2 video and the Dolby AC-3 or MPEG-2 audio. All this requires at least a 300-MHz Pentium II or Macintosh G3 processor.

According to manufacturers, approximately 10 percent to 30 percent of new computer systems with DVD-ROM drives include the decoder hardware. The remaining DVD-ROM-equipped systems include decoder software.

Hardware decoders do not require immense CPU processing power and produce better quality video than software decoders. During operation, the hardware decoders use a video overlay to insert the video into the computer display. The video overlay may take the form of either an analog VGA signal output from the graphics card and keys found in the video or a direct digital connection called video port extension. With VPE, a cable attached to the motherboard connects to the graphics adapter.

Software decoders need a minimum of a 233 MHz Pentium II processor and a DVD-ROM drive that features bus mastering DMA. This becomes necessary in order to achieve the 24 frames per second film or 30 frame per second video rates. For most applications, a video accelerator improves the performance of the software decoder software. The accelerator card improves the decoder performance by taking care of MPEG-2 decoding tasks.

Recordable DVD Technologies

DVD-ROM also includes recordable versions called DVD-R, DVD-RAM, DVD-RW, and DVD+RW. While the DVD-R format can sequentially record data once, DVD-RAM, DVD-RW, and DVD+RW discs may be erased and rewritten thousands of times. The DVD-R format uses the same construction techniques as CD-R discs, features compatibility with nearly all DVD drives and players, and has a storage capacity of 4.7 gigabytes.

DVD-RW utilizes a phase-change erasable format and will work in most DVD drives and players. The DVD-RW format uses a groove recording technique that places address information on land areas for synchronization at write time. According to manufacturers, a DVD-RW disc will accept 1000 erasures and rewrites. New DVD-RW video recorders became available internation-

ally late in 1999. Unfortunately, the recording format used with the new recorders does not permit compatibility with existing players.

DVD-RAM and DVD+RW discs use phase-change technology and are not compatible with current drives because of defect management, reflectivity differences, linking sectors, and minor format differences. The use of a wobbled groove, the CLV format for sequential video access, and the CAV format for random access allows compatibility between DVD+RW discs and existing DVD-Video players and DVD-ROM drives. A wobbled groove eliminates the use of linking sectors in the format. DVD+RW discs will accept 10,000 erasures and rewrites.

Control codes and copy protection

When we consider the use of control codes and copy protection in DVD technologies, we are also considering the economic impact of DVD-Video. Regional codes provide motion picture studios with a method for controlling the home release of movies in different countries. This becomes important because the studios may release screen versions of a movie in Europe well after the video release in the United States. In addition, the movie studios have concerns about distribution rights. As a result, the DVD-Video standard includes regional codes that prevent the playback of certain discs in specific regions of the world. A disc that has the code could be purchased in one country but may not play in another country.

Regional codes remain as an option for the manufacturer of a disc; a disc without codes will play on any player in any country. If the disc includes the region code, the code remains as a permanent part of the disc. The code numbers correspond to eight regions.

DVD-Video manufacturers also apply one of four types of copy protection and have begun to study the use of the same type of watermark protection as seen with DVD-Audio discs. Macrovision adds a rapidly modulated color burst signal and pulses in the AGC to the composite and S-video outputs. The serial copy generation management system, or SCMS, included with each DVD-Video disc prevents copies of copies. Another copy protection standard called the

Content Scrambling System, or CSS, uses data encryption to prevent the reading of media files directly from a disc.

Decryption circuitry in the DVD-Video player decodes the data before displaying the programming on the screen. DVD-ROM drives and video decoder hardware and software exchange encryption keys which allow the decrypting of the video data before the encoder displays the information. The fourth system, called the Digital Copy Protection System, also exchanges encryption keys and uses authentication certificates to establish a secure playback channel.

With each system of these DVD systems, no encryption is required for content that does not have copy protection. The technology relies on flags that mark the content with flags that provide "copy many times," "copy once," "don't

copy," and "no more copies" signals back to the copy protection hardware. Given the capabilities of the hardware, players can authenticate the capability to do nothing more than reproduce audio and video and receive all data.

Conclusion

As this article has shown, the introduction of digital versatile disc technologies has increased the complexity of consumer electronics. Lower prices for DVD players and discs will increase the chances that consumers will need advice about a purchase, call for assistance with an installation, or eventually bring a unit in for repair. This article combines with the article featured in the October 1999 issue of **ES&T** to provide the background knowledge that you will need to cope with those requests and opportunities. ■

ES&T Calendar

2000 National All Service Convention
March 1-5, 2000
Orlando, FL

Electronic Technicians Association
602 N. Jackson Street
Greencastle, IN 46135
Phone: 800-288-3824
Fax: 765-653-4287
E-mail: eta@indy.tdsnet.com
Website: www.eta-sda.com

Home Automation Convention
March 3-5, 2000
Orange County Convention Center
Orlando, FL
John Galanie 703-352-9111

ETA Annual Membership Meeting
May 5-6, 2000
ETA Headquarters
604 N. Jackson
Greencastle, IN 46135, and
The Walden Inn
Greencastle, IN
ETA: 765-653-8262

NESDA 50th/ISCET 30th/NIAS 8th
Annual National Professional Service
Convention and Professional Service
Trade Show
August 7-12, 2000
John Ascuaga's Nugget Hotel
Sparks (Reno) NV

NESDA
2708 W. Berry
Fort Worth, TX 76109-2356

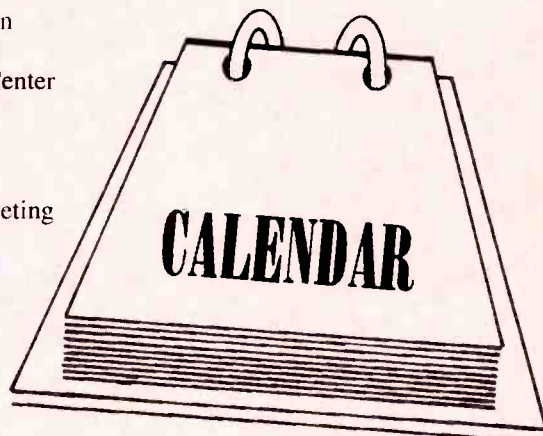

Test Your Electronics Knowledge

by J.A. Sam Wilson

- The condition of a lead-acid battery, also known as a storage battery, is measured with a:
 - hygrometer.
 - manometer.
 - PET.
 - hydrometer.
- What is an absorption wavemeter used for?
 - Measuring wavelength.
 - Measuring standing wave frequencies.
 - Measuring field strength.
 - Measuring the resonant frequency of an LC tank circuit.
- The term "op amp offset voltage" means
 - The output voltage minus its input voltage.
 - Its output voltage minus the input voltage of the next stage.
 - The potential between its input terminals in a closed-loop condition.
 - The potential between its input terminals in an open-loop condition.
- The input impedance of a theoretically perfect op amp is
 - 100Ω.
 - very low.
 - very high.
 - 10000Ω.
- A frequency counter is:
 - a frequency-measuring device.
 - a form of marker generator.
 - a device used to determine if an automatic transmitter is in operation.
 - a device used to generate wideband frequencies.
- How tightly should a dip meter be coupled to the tuned circuit being measured?
 - As loosely as possible.
 - As tightly as possible.
 - First loose then tight.
 - With a jumper wire.
- What does the horizontal axis of a spectrum analyzer display?
 - Voltage.
 - Resonance.
 - Amplitude.
 - Frequency.
- High and low logic states are indicated by:
 - a Wheatstone bridge.
 - a ballistic galvanometer.
 - a logic probe.
 - an electroscopes.
- Which of the following best describes a constant-K filter?
 - One with series-element and shunt-element impedances constant over a wide range of frequencies.
 - One that is shaped like the letter K.
 - One designed for working in the K-band.
 - One that varies over a wide range of frequency sensitivities with a constant current input.
- In the international phonetic alphabet, letters E, M, and S are represented by
 - Echo, Michigan, Sonar.
 - Equator, Mike Sonar.
 - Echo, Mike, Sierra.
 - Element, Mister, Scooter.

Answers to TYEK

- D. The specific gravity of the electrolyte, the fluid between the plates, is measured with a hydrometer. The electrolyte is a mixture of distilled water and sulfuric acid. The electrodes are made of lead and lead oxides. Specific gravity is the ratio of the electrolyte mass to the mass of an equal volume of distilled water at 4°C.
- D.
- C.
- B.
- A.
- A.
- D.
- C.
- A.
- A.
- C.

Photofacts

GE	CT-32G24UA.....4247	SAMSUNG	
CTC185B4.....4250	GP3314247	TXJ25544256	
19GT270TX1.....4250	MBP328.....4257	TXJ25664256	
JVC	PHILIPS MAGNAVOX	TXJ25674256	
AV-32015.....4254	PR1319C1214249	TXJ2567/CCX.....4256	
AV-32015 (Version A).....4254	PR1903C1224259	SHARP	
AV-32020.....4254	RCA	CL20S104255	
AV-32020 (Version A).....4254	CTC185A4.....4248	20L-S100S.....4255	
MAGNAVOX	CTC185AB4251	21ML504255	
VRU262AT21VCR-318	CTC185AB24251	SONY	
VRU342AT21VCR-318	CTC185AB34251	KV-27V424253	
VRU344AT21VCR-318	F19261TX14248	KV-29VL42T.....4253	
PANASONIC	F19262TX14248	SCC-S27M-A4253	
CT-13R30A.....4257	F25216BCTX14251	SCC-S40B-A4253	
CT-13R30CA.....4257	F25216WTTX14251	ZENITH	
CT-13R40A4257	F25217BCTX14251	B27A30ZC.....4258	
CT-13R40CA.....4257	F27242GYTX14251	B32A24Z4252	
CT-32G24A4247	F27243BCTX14251	LGB29A30ZM4258	
CT-32G24A4247	F27244BCTX24251		
CT-32G24CA.....4247			

EXPAND YOUR KNOWLEDGE

Manufacturers Include:

- Hitachi
- Samsung
- Sanyo
- Sears
- Sharp
- Sony
- Thompson
- Zenith
- And More



Professional Reference • 320 Pgs. • 8-1/2" x 11"

ISBN: 0-7906-1207-0 • Sams 61207 • \$29.95

www.hwsams.com • 1.800.428.SAMS



The wait is over!

Electronic Service Data from SAMS is here!

Log on to www.hwsams.com and order E:fact®! You'll have what you need in a day!*

*See Our Website For Important Restrictions and Requirement.

Each E:fact® Electronic Service Data includes the following features:

- SAMS Standard-notation schematics
- Source voltage locations
- Waveforms for important test point locations
- Detailed parts lists for major components
- Placement charts showing component location

All for only \$10.95

Available only at www.hwsams.com

A Bell Atlantic Company
Howard W. Sams
 1.800.428.SAMS

What's new in computer software

by Conrad Persson

We call them computers, but today that's an outrageous misnomer. A better term would be "all purpose information processing unit." Truly, when "computers" were invented that's what they were. Those early computers, rooms full of vacuum tubes and relays, were designed for just one thing — to perform calculations; to compute. Essentially, those early computers were used to compute tables of artillery projectile trajectories. Each calculation, or set of calculations, had to be entered into the computer individually. And it was done by rerouting wires, not by feeding in cards or typing information in on a keyboard.

Compared to the capabilities of a laptop of today, those computers early computers were primitive.

The development of computer "application" software

For years after the introduction of the computer, every computer "program," the set of instructions that causes a computer to perform its task(s), was created individually. Computer hardware was expensive and the effort of programmers was expensive, which made computers prohibitively expensive and the domain of banks and large companies.

Over time, computers evolved, becoming smaller and less expensive, but still out of reach of individuals. Then the personal computer was invented. In those early days, personal computers were certainly useful, but their usefulness was limited. Technical people, who needed their computing power, and could program them, used personal computers.

Computers evolved gradually and became more powerful, but every time someone needed to use the computer, he had to program it, or have it programmed by an expert. Then a couple of business-oriented computer experts decided to try to develop a general-purpose program. Called VisiCalc, this program was a "spreadsheet" program. It consisted of an arrangement of rows and columns and allowed the user to enter text and numbers, and to perform mathematical operations on the numbers.

With the advent of VisiCalc, an accountant, or bookkeeper, or anyone who needed to keep track of large numbers of numbers and perform calculations on them could buy a copy of this "canned" program. They didn't have to know how a computer worked, they didn't have to know how to program, they just bought the program, loaded it into the computer, learned how to use the program, and went about their business.

The explosion of applications

As computers began to advance in terms of computing power, usable memory, permanent storage space (hard drive capacity), use of graphics, sound, power of the operating system and more, more and more software developers began to develop application software. Among the earliest, and most generally useful software were word processing and database



software, which, along with spreadsheet software, constitute the classic office software trio.

Today, the sky's the limit. Walk into any store that sells software and you'll find hundreds of software products for personal computers:

- Cookbooks (with recipes included and space for your own)
- Greeting card creation
- Computer-aided drafting
- Painting
- Model railroad layout
- Astronomy
- Contact (name and address) management software
- Games
- Phone books for the entire U.S.
- Internet software
- Dictionaries
- Encyclopedias
- National Geographic archives
- Photograph enhancement and manipulation
- Page layout
- Communications software that lets your computer answer the phone and send and receive faxes
- Compact disc creation software
- Service management software
- Presentation software (similar to creating a slide show)
- Home layout software
- Landscaping layout software
- Educational software
- Circuit simulation software

A few of the products

Many of these products can be used to improve/streamline the operations of any business, including a consumer electronics service business. Any repetitive task that can be automated, or any task that is similar among managers of many or all busi-

nesses can be captured in a computer that can help and guide a manager doing that task.

Because of the sheer volume of these software programs, it's virtually impossible to present a comprehensive overview of the products. Instead, we'll provide discussions of a few software programs, just to show what's out there, and provide internet links to some sites that catalog software.

The descriptions were provided by the publishers, so you should probably take them with a grain or two of salt. And the editors of **ES&T** don't endorse any of these programs.

Rather than give exact prices, which are subject to change, we give a ballpark figure. Also keep in mind that some of these prices may be discounted heavily in some cases. For example, at Beyond.com, a website that sells many of these products, and from which we adapted the descriptions of the software, ACT!, which we list as "under \$200" as a regular price was discounted to less than \$100, before tax and shipping.

A contact manager

ACT! 2000 contact management software from Symantec (under \$200) gives you instant access to detailed contact and account information, plus a complete history of your contact-related communications and help with managing your schedule efficiently. With this software, you can manage activities for entire accounts as well as individuals. That's in addition to the comprehensive, customizable contact information, including the ability to store notes from meetings and phone calls.

Integration with other business tools lets you use this program to send e-mail through Microsoft Outlook and other e-mail programs, send faxes with WinFax PRO, write letters and memos in Microsoft Word, and enter expenses directly into Quicken ExpensAble (trial version included). Built-in Internet links make it easy to find information to enhance your contact database. The included Palm Pilot Link software keeps you productive even when you're away from the office by transferring information between your desktop and your Palm Computing device. New "sales funnel" graphs help you manage your sales pipeline more effectively.

The program even includes expert assistance from Dale Carnegie Training to help you turn contacts into sales.

Do it yourself advertising

Adams Streetwise DO It Yourself Advertising v1.0, by Adams New Media (under \$30) lets you be your own ad agency and create your own advertising. This software allows a small business manager to walk through the step by step exercises to develop marketing plans, create effective strategies, and produce ads that will get results.

The program, says the publisher, gives you a clear, proven approach for developing successful ads. Starting with the warm-up exercises, and continuing on to the Big Idea Incubator, you'll find a systematic process for jump-starting your own creativity. You'll discover new ways to bring the benefits of your product or service to life and new phrases and ideas to help drive customers to your business.

According to the description of this software, you can create print ads in three easy steps.

1. Choose the ad type: Simply select from Service, Retail, or

Product type ads, and then choose from the powerful layouts available. Each layout can be resized instantly by clicking and dragging the mouse.

2. Fill in the Blanks: Click on the preformatted section to enter text or graphics. You can either choose from suggested items or enter your own.

3. Fine-tune and Print: You can click and drag the different elements to get the exact look you're seeking and then just click to print it out.

Also, according to the publisher, this software gives you interactive tools for finding a source of inspiration to help produce the attention-getting ads that will make your services or products stand out from the competition.

Once you've found your creative approach, the software provides copy writing techniques to turn your ideas into successful ads. Choose from tried-and-true formulas such as the Question & Answer ad, the Demonstration ad, the Spiral, and many more to find the right style for your product or service.

Another feature provides you with all the tools you need to develop effective promotional strategies and marketing plans. You'll get the competitive advantage of putting today's hottest marketing techniques to work for your business.

And, says the publisher, you'll never have to face an empty screen again. Do-It-Yourself Advertising leads you step-by-step through the copy writing process, from generating creative concepts to producing memorable headlines and phrases. Templates and interactive exercises help you get started, and show you how to refine and complete ads that will be consistent moneymakers for your business.

Business finance training

Financial Competence (under \$100), says the publisher, Competence Software, is a multimedia computer based training course for anyone who wants a thorough training in the basics of business finance. Its seven self-paced, self-testing lessons cover how to read, understand, and analyze financial statements and more.

The course is designed for anyone engaged in business who wants to improve their competence by gaining a thorough understanding of business finance basics. Upon completion, the student receives a nice certificate suitable for framing. Available on CD and diskette for single users and, with volume or site license purchases, the course is available for networks, intranets, learning centers, and web based online learning environments. Available for Windows and MAC (diskette only for Mac version).

Learn about marketing using training software

Using the computer software program *Guerrilla Marketing* (under \$40), from Houghton-Mifflin Interactive, you join master marketer and best-selling author Jay Conrad Levinson in a high-energy program to revitalize your business. According to the publisher, this provocative CD-ROM puts the author's revolutionary marketing methods at your fingertips with enlightening information, practical planning tools, and challenging what-if scenarios. It's everything you need to exploit new market opportunities, catch your competition off guard, and develop high-impact marketing plans that get results.

Choose from an arsenal of 25 ready-to-launch marketing weapons. Like any weapon, they must be carefully matched to the campaign objective. Discover how each one works, when it's most useful, and how to best deploy it. Then watch dozens of imaginative scenarios that place you squarely in the role of a guerrilla marketer, challenging you to think more creatively and act more aggressively.

Features include:

- Twenty-five ready-to-use marketing templates
- Strategic planning tools to determine money-making potential
- Print professional marketing plans customized to fit your business
- "Virtual File Cabinet" for easy organization and instant access
- Based on the best-selling series of marketing books by Jay Conrad Levinson
- Guerrilla Marketing Screen Saver

Learn to invest

According to the publisher, Competence Software, their software program Investment Competence is used by some of the largest corporations in the world to train their employees in the basics of investing. It requires no previous investment training. The student who completes this course will be thoroughly trained in all the basics necessary to start on the road to successful investing. Upon completion of the course, the student is awarded a nice certificate suitable for framing.

The course is available for single users on CD or Diskette. For volume discount purchases and site licenses, the course is available in network versions, intranet versions, learning centers, and online learning environments at very low unit costs. This is a solution for training employees who participate in 401(k) and other self directed retirement plans or for anyone who wants to thoroughly learn the basics of investing. Available for Windows and MAC (diskettes only for the MAC version).

Job descriptions

Many small businesses require that job descriptions be written for every member of the staff. It's a good idea, in that it spells out exactly what duties are performed, and what is expected of all employees. But writing job descriptions can be time consuming and annoying to many managers.

You guessed it, there's a software package to assist the busy manager in performing this task; Descriptions Now by KnowledgePoint (around \$120). According to the publisher, with this software it's easy for the manager to go from blank page to finished job description in just minutes.

Just choose from one of over 3500 built in jobs, edit, even combine duties from different jobs. Then answer some questions about physical and educational requirements, work environment, qualifications, and supervisory responsibilities.

Says the publisher, using the software's Intelli-Text™ technology, takes your answers and writes a comprehensive job description that's customized to your organization.

Letter writing software for sales and marketing

Most consumer electronics service centers spend at least some time sending out direct mailing pieces for marketing of

the business. Because other duties take up a lot of time, often managers don't spend enough time performing this important task (or they don't do it as well as it should be done), and business suffers. Programs such as 2001 Sales & Marketing Letters (less than \$30) from Model Office can help make the time spent writing letters promoting the business more effective.

According to the publisher, this practical tool equips you with over 2,001 ready-to-use sales letters and memos for almost every sales and marketing situation. Just choose a topic, and the program will instantly give you example letters, plus guidelines, alternate phrases, and tips from an expert.

Software help managing people

According to Knowledge Point, the publisher of People Manager, (about \$120), in today's legal environment, you're risking your business if you fail to keep accurate personnel records or document actions like hiring, promotions, reviews, and termination. This software product is designed to make it easy to handle routine employee management tasks.

The program centralizes your employee information and helps you perform day-to-day employee-related tasks. What's more, it protects your organization in the event of an employee dispute by encouraging you to handle and document events appropriately. And, it alerts you to the legal significance of issues surrounding employee management.

Help writing performance reports

No manager relishes writing performance reports. Everyone wants to make sure that the performance reports that they write describing the people who work for them are fair, accurate, and complete. Somehow it seems that every time performance review time comes around, it's like doing it again for the first time. Performance Now Enterprise edition (about \$250), by Knowledge Point, provides help to managers in getting the performance appraisals written

Says the publisher, from providing valuable day-to-day feedback, to writing meaningful performance reviews, to providing effective coaching, this software supplies the framework for implementing a comprehensive performance management system that aligns employee focus with corporate objectives.

The software is made up of four core modules. The Form Designer and Application Administrator supply powerful tools for designing, implementing, and monitoring your performance management system. The Performance Manager and Performance Appraiser give managers valuable tools and just-in-time training to help them better manage and develop their people. The result is an integrated approach to performance management that results in consistency and focus throughout all segments of your organization.

Personnel policies

Employee handbooks are crucial to the success of any business. Policies Now! (About \$120) from KnowledgePoint allows managers to create personnel policies customized to their organization. According to the publisher, this software allows you to create an entire employee handbook in a fraction of the time you would normally spend.

This program takes the time consuming task of writing legally-appropriate employee handbooks and cuts it down to

size. Not a "one-size-fits-all" template, this software actually writes policies customized to the needs of your organization.

Its simple, interactive process gets you up and running in no time. Simply choose from a comprehensive list. The software provides an overview of the policy and gives you expert advice about a range of related issues. This advice is researched by top employee law and human resources (HR) experts.

Then it asks you a few key questions, providing guidance all along the way. Based on your answers, the program actually writes a customized policy.

An optional subscription service, UpdateService provides software updates at least twice a year so your policies will stay in compliance with the latest federal laws and court decisions. It will also keep your handbook in step with evolving HR practices. UpdateService also includes a quarterly newsletter with articles on the latest legal trends and the practical side of personnel issues, like how to implement tough policies.

Project tracking software

Not every manager has to manage large, complex, projects. But if you do, there's personal computer software for that too. Project 98 for Windows 95/98/NT by Microsoft (about \$440) allows managers to plan and your projects more effectively.

With the flexible new scheduling engine in this software, you can plan and track your projects more effectively and identify and respond to conflicts before they happen. Schedule and track project information by hour, day, week,

or month. And use the program to model resource and cost information so you can adapt to scheduling changes.

Improve coordination with all the members of your team by consolidating multiple projects to view cross-project dependencies and multiproject reports.

Communicate your plans easily.

This software, according to the publisher, has rich presentation features, such as customizable Gantt charts that you can publish to your intranet or the Internet, to ensure that your plans are noticed and understood.

In addition, this software keeps your entire team informed and involved with the powerful workgroup and intranet support. It enables you to share information, delegate tasks, and track project statuses over electronic mail, your company's intranet — even over the Internet.

Learn from the experts

Much computer software is written by, or with the assistance of experts in the field to which the software applies. So, when you load up that marketing program, or the financial guidance product, or any of the other programs, you're invoking the experience of the individuals who were involved in its production. When you use the best of this software, it's like that person is by your side, giving you guidance in performing that task. The time saved can be significant, and the results can be superb. It might pay to browse one of the websites, like beyond.com, or take a walk through your local computer store to see what else is available. ■



Electronic Technicians Association - ETA

and
Satellite Dealers Association - SDA
present

The **Ultimate Customer Service Specialist Study Guide**

CSS-2

The second edition of this popular CSS Study Guide is now in print.

-  Twice the number of pages
-  Twice the chapters
-  Dozens of new practice quiz questions

Sales-marketing-service relationships; Technoliteracy; Safety; Company standards; Dependability; Teamwork; Work ethics; Problem solving; Company loyalty; Telephone techniques; Controlling your emotions; Communications; Record keeping; Safety; Decision making; Customer service techniques; Hygiene, and more

No Service Business Should be Without One of These Unique Guides to World Class Service!

to order
Call 800 288 3824

eta@indy.tdsnet

ETA-I

602 N Jackson, Greencastle, IN 46135

Circle (64) on Reply Card



SERVICE MANAGEMENT SOFTWARE

- Electronic Claims Processing
- Inventory Control with Parts Cross Referencing
- Graphical Calendar for Scheduling
- COD / Warranty / 3rd Party Invoicing & Tracking
- Password Protected User Profiles
- Prints on NARDA & NESDA Forms
- Auto Labor Rates by Product or Model Number
- Quick Record Look-Ups and Browsing
- Over the Counter Point-Of-Sale
- Technician Production & Assignment Reports
- Multi Account Tracking & Reports
- Daily Close-Out Reports
- Service Literature Cross Referencing
- Fast Service Reports with Symptom & Fixes
- Unit and Store Status Reports
- Supports Unlimited Number of Users on a LAN
- Pro-Validates Warranty and 3rd Party Claims
- True 32 bit for Windows95 / 98 / NT 4.0
- Much, Much More . . .

**True 32 Bit
for Windows**

Modular Program Design

Will allow you to purchase only the Modules you need and add other modules at any time.

FREE DEMO

(800) 451-0137

2535 Putty Hill Ave.
Baltimore, MD 21234
www.custom-dat.com

 **Custom Data Associates**

Circle (60) on Reply Card

Technology: Battelle forecasts strategic technologies for 2020

by the ES&T Staff

Forecasting the future is risky business. In the past, forecasters have predicted that we'd have flying cars, and a lot of other exotic technology, which has not arrived. But nobody predicted personal computers, cell phones, or the internet. Recently, **ES&T** received a press release from a company called Battelle, saying that technology experts at Battelle think they have 2020 vision. They don't mean perfect eyesight today. They're talking about the ability to see what the world of 2020 may look like.

A team of top scientists and engineers at Battelle, a world renowned technology organization based in Columbus, Ohio, has compiled a list of the 10 most strategic technological trends that will shape business and our world over the next 20 years. We thought that readers might be interested in what these experts envision 20 years in the future.

And what do the Battelle experts see?

These experts see a world of microscopic, cancer-eating machines, cloned human organs, designer foods, and computers everywhere. Some of these computers may even be embedded in your clothes and under your skin.

"The 20th century was the time of big technologies, mass production, mass wars, and mass politics," says Stephen Millett, thought leader and manager of Battelle's technology forecasts. "But in the years ahead, new technologies will become much more personalized, and they will closely affect almost every aspect of our lives."

Millett adds, "We see advances in information and biological technologies bringing us into a more intimate relationship with nature and with each other. From cloned human organs, to personalized public transportation, to computers embedded in our bodies, we will become intertwined with technology."

The 2020 technology forecast follows a series of 10-year forecasts Battelle initiated in 1995. "Those lists are turning out to be quite prophetic, and maybe even a little tame," says Will Kopp, a futurist with Corporate Communications, of the forecasts that predicted technologies such as multi-fuel automobiles and flat-screen, high-definition television. "With the

dawning of a new millennium, it's valuable to look ahead a little further and identify powerful technology trends."

Battelle's list of the top 10 technologies for 2020 follows

1. Genetic-based Medical and Health Care

Over the next 20 years, we will witness an explosion of medical technology originating from genetic research, giving us the ability to detect and correct many genetic-based diseases before they arise—possibly even in the womb.

A wide range of new pharmaceuticals that originated from genetic research will come onto the market in the next 20 years, leading to treatments, cures, and preventive measures for a host of ailments. These products may range from treatments for life-threatening diseases to psychological disorders to cosmetic problems.

Some of these treatments will be personalized to meet the unique needs of an individual's genetic makeup.

"Your doctor might have a record of your genetic makeup," says Eric Majewski of Medical Products, "and he or she might be able to prescribe medications, diets, or other treatments to fit your own particular needs. It will really be the ultimate in individualized medical care."

Battelle forecasters say genetic research also will lead to cloned human organs within 20 years. These organs will be grown and used in transplants.

2. High-power energy packages

Developments such as highly advanced batteries, inexpensive fuel cells, and micro-generators of electricity will make many of our electronic products and appliances highly mobile. Decentralized power sources will be extensive, affordable, and environmentally clean.

These new, high-power, distributed energy systems will provide backup if not primary energy sources for appliances, homes, and vehicles. In the transition to fuel cells, we will see further improvements in batteries — perhaps linked with solar power—and small generators fueled by natural gas.

3. GrinTech (Green Integrated Technology)

Global crowding, fears of global climate change, and mountains of garbage will thrust environmental concerns to the forefront of consumers and industry around the world. Technology will provide the answers, with new systems that eliminate rather than reduce waste.

"The integration of a variety of technologies is the key here," says Gerry Stokes, Associate Director of the Pacific Northwest National Laboratory. "We'll be using advanced sensors, new materials, computer systems, energy systems, and manufacturing technologies to eliminate waste and make our products completely recyclable."

GrinTech will be especially important in agriculture, mining, manufacturing, and transportation Systems.

4. Omnipresent computing

Computers will be everywhere. We will be in constant contact with very miniature, wireless, highly mobile, powerful, and highly personalized computing with network access.

Such computers may first appear on the market as watches or jewelry with the power of a computer and cellular phone. Later, we will have computers embedded in our clothing and possibly implanted under our skin.

5. Nanomachines

Microscopic machines, measured in atoms will revolutionize several industries and may perform a wide range of jobs for us — from heating our homes to curing cancer.

Battelle researchers see the medical industry as the most important area for nanomachine technology by 2020. "We may be able to develop nanomachines that will go into your body and find and destroy individual cancer cells while not harming healthy cells," says Battelle Senior Research Scientist Kevin Priddy. Nanomachines also could be used to deliver drugs to highly localized places in the body, to clean arteries, and to repair the heart, brain, and other organs without surgery.

6. Personalized public transportation

The continuing growth of cities will further stress our transportation infrastructure. Yet, Battelle researchers say an aging population with concerns about safety, convenience, and independence will help maintain a high demand for personal vehicles. The challenge is to integrate many individual cars within a coordinated and optimized public transportation network.

"Realistically, public transportation systems like trains and subways are the most efficient way to move people around in a dense urban setting," says Millet. "But many of us don't want to give up our cars. So, technology will help us turn our cars into what will almost be personalized public transportation."

New information technology in your car will work with a central traffic control system to guide you through the quickest route to your destination. Traffic jams and road rage will decline substantially as people drive their cars to remote parking areas and take highly advanced-and comfortable-trains into central cities and between cities.

7. Designer foods and crops

Grocery store shelves will be filled with genetically engineered foods that are environmentally friendly and highly nutritious. Through genetic engineering, researchers will develop crops that resist diseases and pests, greatly reducing the need for pesticides and other chemicals.

Battelle predicts that most food sold in supermarkets will come from genetically engineered fruits, vegetables, and livestock. Nearly all cotton and wool or fabrics for our clothing will be genetically engineered.

Even lawns could be genetically engineered to need less fertilizer and pesticide and — best yet, grow more slowly.

8. Intelligent goods and appliances

Advances in quantum computing will lead to smaller, more powerful computers and electronics that will add amazing intelligence to appliances and other products.

These intelligent products will likely include telephones with extensive phone directories, intelligent food packaging that tells your oven how to cook the food inside, refrigerators that help make out your shopping list and tell you where to get the best price on the food you need, and maybe even a smart toaster that won't burn your toast.

9. Worldwide inexpensive and safe water

Within the next 20 years, clean drinking water could become an expensive commodity around the world. However, before water shortages become critical, technology will answer the challenge, with advanced filtering, processing, and delivery of potable water. Desalination of water and water extraction from the air are two possibilities.

"Our most important technological challenge of the next two decades may be developing new ways to make clean water plentiful and inexpensive around the world," Kopp says.

10. Super senses

One of the hot technologies today is virtual reality. In 20 years, though, we will be marveling over "enhanced reality." Using sensors and electronic or genetic technology, we will be able to implant devices that will allow us to hear better than ever before or see farther or in the dark.

Gerry Stokes says the technology will first be used to enhance hearing. Baby boomers have lived in a very noisy world — with rock music, airplanes, construction equipment, lawn mowers, and other assaults to their hearing. And as they age, we'll see a rash of hearing problems," Stokes says. "We'll be able to repair that damage, but why stop there? Why not make their hearing better than it's ever been?"

Battelle, headquartered in Columbus, Ohio, focuses on technology development and commercialization and product development. With 7,000 employees at more than 60 locations, Battelle develops technologies and products for industry and government. For more information on Battelle and its technology forecasts, visit Battelle's web site at www.battelle.org. ■

Speaking about speakers

by Alvin G. Sydnor

It is unfortunate that so many personal prejudices and economic considerations enter into the discussion of tone quality of audio reproduction systems. We all know that music appreciation is largely a matter of conditioned reflexes. In the current trend involving CD and digital audio, there is a danger that these innovations may dull our senses and limit the scope of pure tone appreciation. There is also an unwillingness to pay for high quality sound.

Today's technology has made it possible to design and mass produce top quality audio amplifiers, speakers, and input devices that can provide almost any desired frequency response. By the use of suitable filter networks, it is not difficult to compensate electronically for the response curve of the ear at different intensity levels as well as for frequency range limitations in many custom built audio systems. The variations with frequency in sound pressure from a loudspeaker are too violent to be disposed of in a practical sense. The point that I am trying to make is that the selection and design of a loudspeaker system and its enclosures deserves more attention than any other component in the audio reproduction system.

Better speakers, better sound

The difference in the quality of the end results when using a quality speaker is often greater than most people realize. We are now in a new era that is demanding quality sound reproduction and there is intense research and development going on to provide better equipment and components for quality audio recording and reproduction. This trend has pushed the development of improved and inexpensive loudspeakers that are capable of faithfully reproducing the bandwidth that the listener wants and enjoys.

Sooner or later, the electronic technician specializing in audio systems will be faced with the serious dilemma concerning "brand-name" vs. "brand X"

Sydnor is a retired consumer electronics servicing technician.

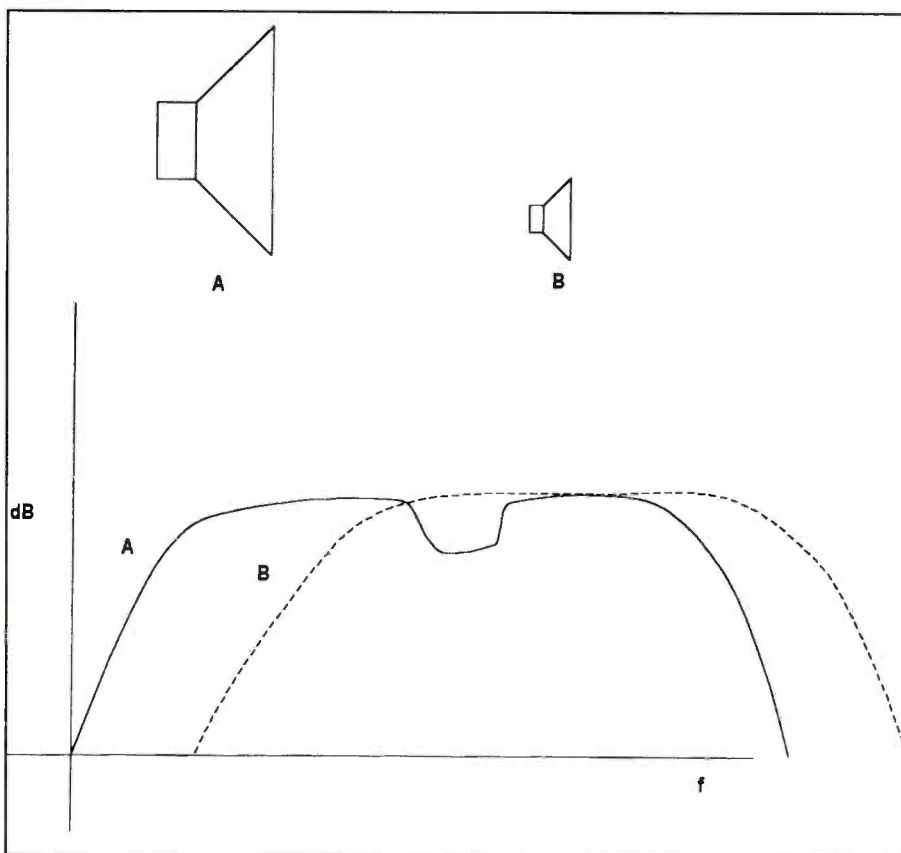

Figure 1. Low frequency performance is more easily obtained from a large speaker than from a small speaker.

products. There are many who would not like to take their chances on unknown or the newcomer to the field. It is possible to get a good loudspeaker system from a relatively unknown manufacturer since many of them adhere to the same design principles and manufacturing techniques that the brand name manufacturers do. It may come as a surprise that many of the high quality brand name speaker manufacturers supply components and technical know how to many small manufacturers of what we call brand X speakers.

Loudspeaker qualities

It is not the author's intention to get into the marketing strategy of speaker manufacturers but rather cover the principles involved in designing a good speaker regardless of whether it is a well

known brand name or a private label system. Before proceeding, it would be well to review just what requirements we want and expect from a satisfactorily designed loudspeaker.

The loudspeaker should be reasonably free from waveform distortion and at every instant it should produce a waveform of sound pressure that exactly corresponds to the waveform of the electrical voltage impressed on it at that instant. It should also be reasonably free from frequency distortion, which means that it must respond uniformly throughout the audio frequency range which is applied to its inputs.

Another requirement is that a loudspeaker should have a linear response with respect to the strength of the signal voltage being applied to it. This means that its sound output must be directly

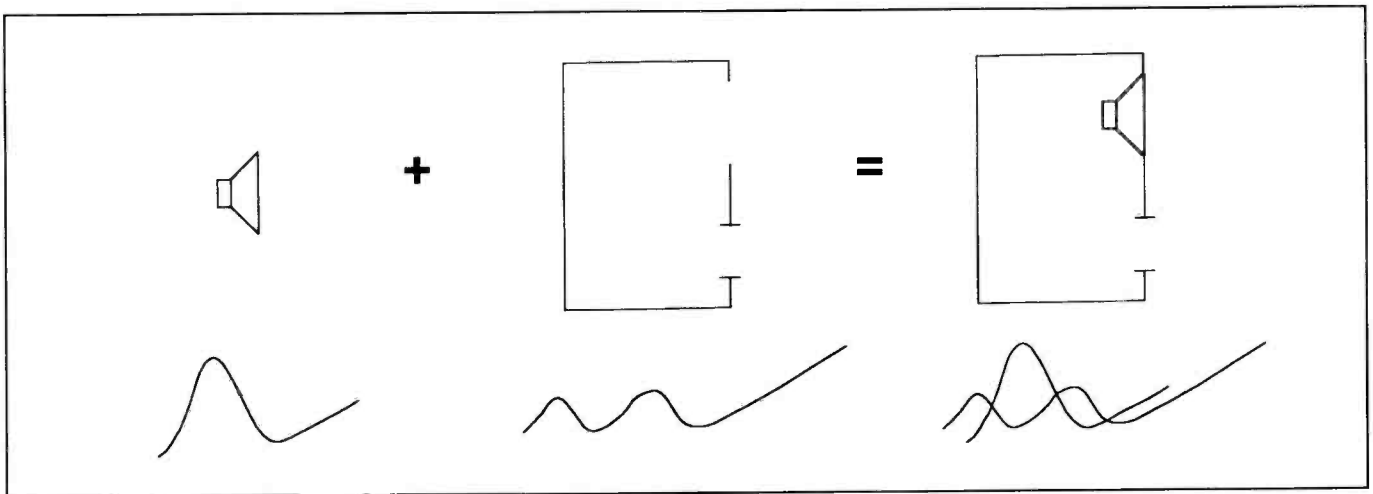

Figure 2. A speaker enclosure extends the frequency response of the system.

proportional to the value of the electrical input, or in other words, it must be free from volume distortion over the volume range required. Of course, it must also be able to stand the ordinary amount of abuse and misuse and should be economical in cost as well.

The question of frequency distortion of a loudspeaker is a rather flexible one, since it is possible to obtain very satisfactory overall results with a loudspeaker whose frequency response is not uniform, simply by designing the amplifier system with a non-uniform frequency response that corrects the shortcomings of the speaker. This was a very common procedure many years ago.

I think that if we analyze the components that make up music, we can have a better insight into what the speaker has to deal with. Music has the characteristics of frequency, loudness, and tone. Looking at each, it becomes obvious that tone quality is the major component that can seriously affect frequency response.

What makes good sound?

All Scotch whiskies do not taste the same, but the distiller, despite the fact that it comes from the same basic materials, interprets his conception of what is right. It is my considered opinion that manufacturers of repute manufacture loudspeakers that, in their opinion, take the correct approach to their design. Now we come to one of the most often asked questions: "Why do two supposedly good high quality speakers often sound so different from each other?"

The answer to that question may be simply that the brand X speaker was designed to cater to those who like lots of bass and the brand Y speaker was designed for those who want less bass, thus the designer's choices are different. The ultimate result is what I term the "personality" of the speaker.

It is a fact that different people like different drinks, and not everyone wants to drive the same car, nor do we all hear the same. To some degree, it is fortunate that all loudspeakers do have different personalities, which is a plus, in order to satisfy the widely varying requirements and tastes of the listener.

Mystique

There is more mystique involving loudspeakers than any other component in the audio reproduction chain. The speaker is a legitimate component and it has the simple job of converting the near-to-perfect electrical signal from the amplifier into an equally perfect acoustical signal within a room.

What is often overlooked is that a loudspeaker pushes and pulls air, thus causing it to move in the same manner as when the original sound was produced. The loudspeaker as a transducer has certain transduction losses; the signal that goes into a speaker is not necessarily the signal that comes out.

Frequency response

The most familiar speaker specification is its frequency response, and we all know that high frequency response is

necessary to bring out the fine overtone structure of any component in the system. To the speaker design engineer, it becomes a real challenge to obtain a wide frequency range particularly when limited to a single speaker, but it has been done and it is possible to obtain some reasonably good sound reproduction from a single speaker. The first thing we must determine is the frequency range necessary for quality music reproduction. Throughout the years, we have accepted the frequency range of the human ear as 20Hz up to 20,000Hz.

As we all know, high frequency response is necessary, but we also must keep in mind that the frequency response curves themselves are by no means a complete measure of the performance of a loudspeaker. These curves are to be used as guides by technicians and acoustic engineers in order to improve and develop better loudspeaker systems. Among the many factors which are not apparent on these response curves are spatial distribution, transient response, and harmonic and inter-modulation distortion. The subjective performance is affected by these factors along with frequency response. When two speakers with identical response curves operating in the same system do not sound alike, this can be due to these same factors.

Spectrum distribution

Spectrum distribution, which is sometimes referred to as polar behavior, must be uniform at various angles from the axis of the speaker. If the polar pattern is

irregular, the response balance will change as the listener moves off the axis of the speaker. The most desirable condition exists when the overall pressure drops off the axis while uniform response is maintained. Polar behavior of a conventional cone-type speaker is often very poor at high frequencies, while non-directional at the low frequencies where the wavelength is very large compared to the diameter of the cone.

There are several sources of distortion produced by cone type speakers. One type is called cone-breakup at high frequencies, which is caused by the use of lightweight cone material that does not possess sufficient rigidity to suppress spurious modes of vibration. When cone break-up occurs, the cone does not move like a piston as it is supposed to, thereby causing objectionable sub-harmonic

tones. The selection of the proper cone material and manufacturing techniques to obtain sufficient cone mass are used to reduce flexing of the cone during its normal operation as a reproducing device.

Another major problem with loudspeakers is distortion, both harmonic and intermodulation. Intermodulation distortion is especially serious since it results in the sum and difference frequencies, which are not harmonically related to the fundamental tone. This is very displeasing to the ear.

Guidelines for selecting a loudspeaker

What are the guidelines in selecting a loudspeaker? I will outline those that I feel are important. The first consideration must be size, the second is cost, and the most important is the quality of the

sound that it reproduces. A good loudspeaker should reproduce its input as well as the systems input and it must sound natural in doing it. It should also not sound heavy in the bass, nor shrill and strident in the high-frequencies nor should there be much "hissing." A low price speaker may sound better than one that is priced at twice the cost. Don't automatically assume that quality is equated with cost.

Speaker size

Whenever there is a discussion among acoustical engineers, technicians, and sound technicians on the question of speaker size there will be many opinions. As shown in Figure 1, the lower frequency performance is more easily obtained from the larger speaker than from the smaller speaker. The acoustic

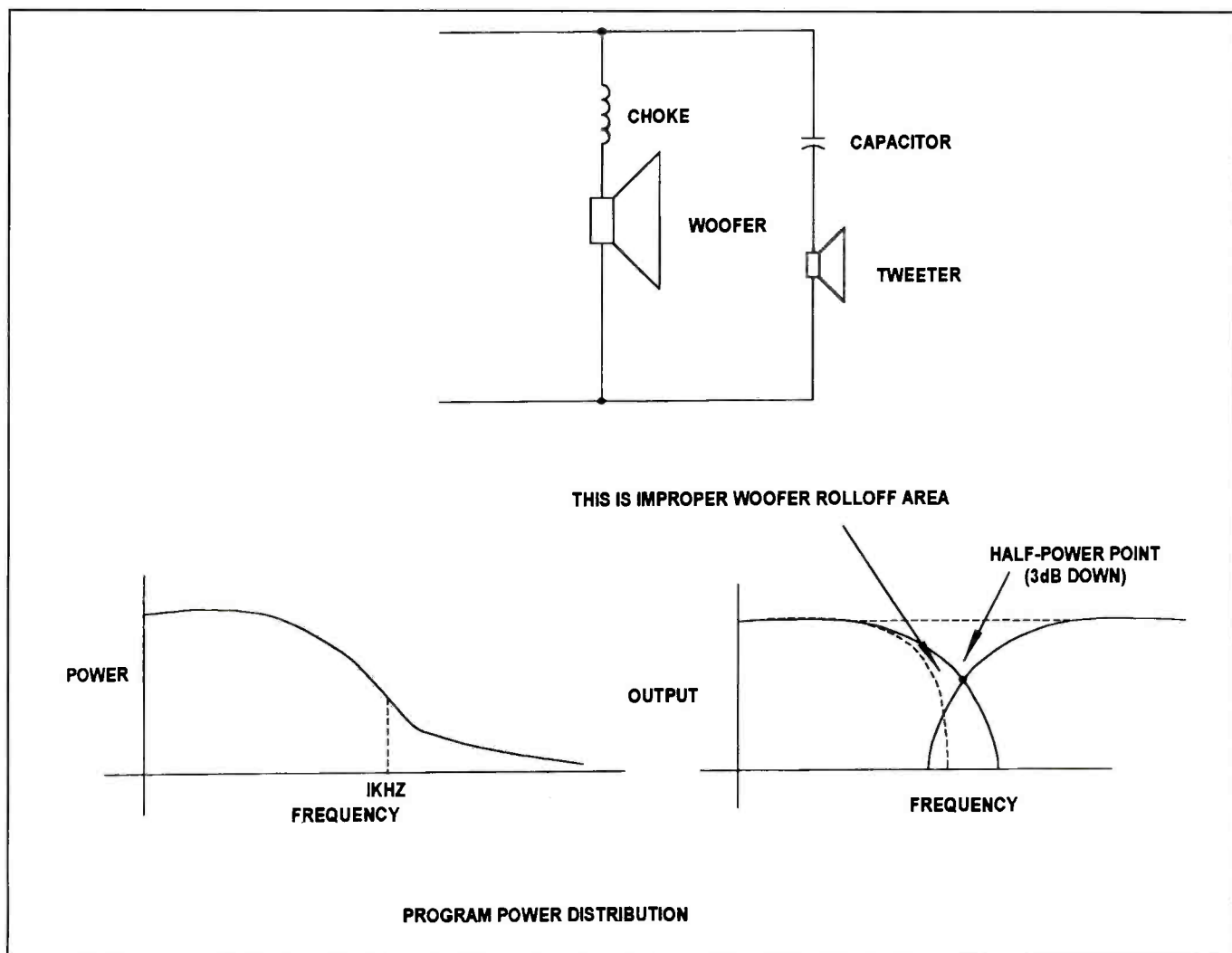

Figure 3. A crossover network directs the various frequencies to the appropriate speakers.

output of the cone's diameter in relation to the wavelength of the sound being reproduced indicates that the larger the ratio of diameter to wavelength, the larger the radiation resistance as seen by the cone movement, the greater the output.

A larger diameter cone will have a higher radiation resistance for a given low-frequency wavelength than a smaller diameter cone. Since radiation resistance determines the acoustic power output, the larger diameter cone will provide better sound output for a given low-frequency wavelength. So we can say that speaker size relates to frequency response and power handling capabilities.

Dispersion characteristics

The dispersion characteristics of a loudspeaker system may have a profound effect on the quality of the sound you hear. Most speakers tend to narrow down in dispersion width as the frequency goes up. Most audio technicians are familiar with the type of speaker that sprays high frequencies like a high velocity garden hose. This effect can reach the point where the sound is extremely unpleasant. Bass dispersion is no problem since bass is going to disperse.

Power handling capabilities and impedance

When dealing with the subject of loudspeakers, I doubt if there is an area that presents as much confusion as that of the power handling capabilities and impedance. Care must be exercised in considering speaker power ratings. You must make sure that the speaker is capable of handling the total power output of the amplifier thus avoiding damage to the speaker as well as the amplifier.

Another numbing figure that is often tossed about is the impedance rating of the speaker. Most reliable speaker manufacturers are realistic enough to specify impedance as "*nominal impedance*." You must keep in mind that the impedance of most speakers will rise significantly as the input frequency is lowered toward the resonance point. So never assume that a speaker's impedance is fixed or the frequency response curve you get with the speaker is flat over the frequency range specified.

Effect of low impedance loads on amplifiers

Some audio power amplifiers cannot tolerate extremely low impedance loads. Such amplifiers will not operate to complete satisfaction with a 4Ω load because the speaker's impedance actually dips below 4Ω at the bass or in some cases at the mid-range end. The lower the impedance, the higher the output power.

A given set of output transistors can only deliver so much power before their maximum current rating is exceeded, therefore lowering the impedance of the speaker below the minimum recommended value (usually 4Ω) may result in output losses, or damage to the protection resistors so that they'll have to be replaced fairly frequently.

To see how impedance affected power output, I recently ran a test on an amplifier with an input set at 1Kz which was delivering 5W to the speaker and, because there was a dip in impedance at 5Khz input, the amplifier was delivering 25W. When this impedance dip occurred, the sound became a bit peaky, and when played at this high power level, pop went the protective resistors.

Matching the speakers to the amplifier

It is very important that the audio technician keep the following important points in mind when dealing with matching the speaker to the amplifier:

- The speaker must have the proper impedance value that matches the amplifier output impedance, otherwise you risk distortion, reduced power or increased loading that could blow the output transistors.
- Speaker impedance varies with frequency. The minimum impedance should not be less than 75% of the rated value
- When using tweeters, especially electrostatic units whose impedance goes down with an increase in frequency, make sure that the minimum value of impedance is not below the minimum load permissible for the amplifier.

Efficiency

Basically, whenever the voice coil is outside the gap, the speaker is considered relatively inefficient. A high-efficiency speaker is one on which there is a near-perfect coupling between the voice coil

and the gap energy, which occurs when the voice coil is almost exactly the same dimensions as the gap itself, so that as it moves in and out of the gap only a small bit of the coil leaves the gap.

If the voice coil is overdriven, part of the coil would be out of the gap. Most coils have been designed to overlap the constant flux area under which conditions the same proportion of the coil will always remain within the gap so that there will be a uniform push or pull on the coil for its normal excursion.

It should not be inferred that a low efficiency speaker is a poor one. On the contrary, low-efficiency speakers can provide excellent low-frequency output, but at a lower level than a high-efficiency speaker for a given power input. Low efficiency drivers are often used in speaker systems as woofers and high-efficiency units are used where high frequencies are reproduced.

In speaker design, the engineer must strike a balance between the low frequency area in which the speaker is to be used, which determines the degree of coil overlap and the high frequency area which requires optimum coupling between coil and gap.

Distortion

So far in our discussion, we have touched on some forms of audio distortion that can be caused by the movement of the speaker voice coil into a region of a non-uniform magnetic field. In most cases, the solution to this problem is a properly designed magnetic structure and voice coil such that the conductor length is a constant, even at high amplitudes. The cone suspension system must be properly designed to avoid non-linear stiffness effects, which will give rise to harmonic distortion.

At the resonant frequency of the moving coil, the mechanical impedance reaches a minimum and the cone attains its maximum movement. The greatest distortion normally occurs at the resonant frequency because within this region of the spectrum, the suspension system is the controlling factor.

There are speakers on the market that have been designed with non-linear suspension systems for the very purpose of giving greater apparent loudness but this type of speaker also gives rise to high

distortion. By critical listening over a period of time, it can be observed that this type of loudness boost is undesirable, since the sound is characterized by audio enthusiasts call "muddiness."

Speakers that use magnetic fields of low-energy levels, particularly those speakers that are being driven by amplifiers with high internal impedance, will produce a false bass response due to undamped vibrations of the cone. All of this results in what I call "hangover," a phenomenon that prevents the reproduction of clean bass response.

There are a number of methods the speaker manufacturer can employ to prevent "hangover." Magnetic damping is by far the best method, but it is very expensive. However this approach does give a much better damping characteristic over the whole audio reproduction range than any other method.

Transient response

When looking at a speaker's response curve, the audio technician must be aware of the curve's main weakness, in that it does not show the speaker's transient response. Whenever a sharp spike or a square-wave pulse is fed into the speaker, the transient point appears.

What really happens is that the mechanical parts, such as the voice coil system and the cement joints of the cone, flex and fail to respond to such sharp spikes. So we can say that we want a speaker that has the ability to faithfully respond to any suddenly applied signals and to clearly and quickly come to a full stop when the signal stops.

Most all the transient pulses (tones) cause the speaker to encounter over-swings at the start of the tone and have a trailing decay at the end. The lack of good transient response of a speaker causes muddiness of tone, especially for percussive tones and a blurring of notes during a very rapid passage of music.

Good transient response of a loudspeaker is a function of its magnet weight, or to be more precise, it's the flux in the gap, so to choose a speaker that can handle transient response, look for a high weight magnet. From a practical point of view, when a speaker cone and voice coil have been put into motion by means of an input signal, it becomes an electric motor. In fact, many years

ago, speaker design engineers often referred to a loud speaker as a loudspeaker motor. This analogy does make sense since all electrically energized components that have moving copper in a magnetic field generate a back voltage that tends to oppose the voltage signal causing the initial action of the device.

In the case of the loudspeaker, a signal input starts the system moving and it will continue to move forward on its own free will unless it is subjected to some braking force which is the degree of back voltage generated. If the magnet is weak, the reaction will be weak and the diaphragm will continue forward in an unrestrained overshoot condition.

If the magnet strength is great (high weight), there will be a strong reaction to the driving signal and it will surge forward only to the extent that the signal tells it to without any over-ride due to its own free undamped motion. So we can say that a well damped speaker will give us good transient response during both the attack and decay times and good damping is obtained by heavy magnets.

Most manufacturers specify magnet weight. Some inexpensive speakers have rather large covers over the magnet in order to make them appear as though heavy magnets are under the cover.

The enclosure

Its important to look at the enclosure as a coupling device. With the exception of one or two specialized types of speakers, most all speakers need to be enclosed in some sort of baffle or cabinet which is especially true of the woofer. In this case, a baffle is not just a decorative box for the speaker. The baffle is a device that performs two major technical functions. It is a frequency controlling device as well as an acoustic damping device.

As shown in Figure 2, we can see this dual-control action of a bass-reflex type of enclosure. The large resonant peak of the speaker disappears (are damped-out) when the speaker is put into an enclosure specifically designed for it. In place of this resonant peak, two smaller peaks are produced. With each peak displaced approximately an octave on either side of the initial resonance peak, the low-frequency response of the system is extended. It must be emphasized that the

enclosure is truly an acoustic network that is designed to match the driver energizing it. Any time you indiscriminately mount a speaker in a box, it is not necessarily a matched system.

Crossover networks

Multi-speaker systems require "frequency-controlling" devices which are known as crossover networks. Figure 3 is a crossover network that has two reactive elements: a choke and a capacitor, each serving a very important purpose. The choke prevents high frequency power from being wasted in the woofer, and the capacitor keeps the low frequency power from being transmitted to the tweeter.

Figure 3 shows how power is distributed over the audible frequency spectrum; with most power in the low frequencies. This is one of the most important reasons for selecting a high-efficiency tweeter. To keep the highs from being lost in the woofer, a series choke coil is used, but you cannot use any old choke coil or capacitor indiscriminately in a crossover network.

Roll off characteristic

The roll-off characteristic is the rate at which the high frequencies are rolled off by the choke and the low frequencies are rolled off by the capacitor. It is very important that these two points be such that they cross over in approximately the area where the curves are 3-dB down from their flat or at the half-power points. Care must be exercised in coordinating the rate of roll-off of the speaker and its roll-off characteristics at the desired crossover point in order to give a smooth curve resulting from the combining of the woofer and tweeter characteristics.

Good sound becomes more important

With the advent of home theater, with all the spectacular sounds that accompany movie action, and with the availability of high quality sound sources and amplifiers, the quality of the speakers becomes more and more important. The more a consumer electronics technician knows about speakers and speaker systems, the better he'll be able to make sure they sound as good as they can, and to find out what's wrong when they don't. ■

Zenith Model SM2726EWM

by Steve Babbert

A good way to get ahead in servicing is to take steps to find out in advance what kinds of problems you will most likely encounter in the future. This can be difficult with such a wide variety of so-called new and improved designs coming down the pike; a testament to the fact that engineers all seem to have different ideas. By familiarizing ourselves with new designs as they appear, we will have an advantage when they turn up on the bench. With this in mind, let's look at the switching power supply used in a Zenith TV model SM2726EWM.

Basic operation

The switching power supply, sometimes referred to as an SMPS (Switched Mode Power Supply), operates essentially the same as the familiar scan-derived power supply found in virtually all televisions. A switching device is connected between the low side of a transformer's primary winding and ground. Raw (unregulated) dc is applied to the high side. Switching the device on and off creates an ac waveform in the primary which induces ac voltages in the secondary windings. The scan-derived supply generally employs a bipolar transistor (the HOT), whereas the switching supply may use a bipolar transistor or a MOSFET.

The switch is driven by a driver circuit, which utilizes PWM (Pulse Width Modulation) or PRM (Pulse Rate Modulation) in order to raise or lower the output voltage. The driver circuit has a control block, which compares a sample of the output voltage to a stable reference voltage and then adjusts the driver to make corrections. The sample or feedback used for comparison may be coupled directly or through an optoisolator.

The control block may also have start-up and shutdown functions. Start-up is usually controlled by the syscon (system control). Shutdown usually relies on feedback from the horizontal output sec-

tion, but it may also rely on feedback from the switching transformer itself. Excessive loading due to a short or leakage in a component powered by the secondary supply may cause shutdown.

Advantages to using a switching regulator

There are several advantages to using a switching regulator. Since the switching device is either on or off (saturated or in cutoff), it dissipates less power and generates less heat than a linear regulator. The high frequencies involved translate to a reduction in transformer size and smaller filter capacitors in the secondary supplies. Some of the load can be taken off of the horizontal output transformer by using additional secondary windings on the switching transformer to power various sections of the TV.

The power supply in the SM2726EWM

The switching supply in this chassis is centered around ICX3431, an STR53041 linear voltage regulator (See Figure 1). This IC is very similar to the five-terminal linear regulators that have been discussed in recent issues of *ES&T*. It contains an error detector with a Zener reference, an error amp, and a series pass transistor (See Figure 2). In fact, there is nothing in this IC capable of generating a switching pulse on its own.

Switching transistor Q3431 and various components including a winding on switching transformer TX3431 form a feedback-type oscillator. The waveform at the collector of Q3431 is applied to the base of the series-pass transistor, which acts as a switch. The switch is also influenced by the rest of the circuitry in the IC. In effect, the regulator is being forced into switched-mode operation.

The collector of the NPN switch is connected to the low side of the switching transformer's primary winding through pin 3. The high side of the winding is connected to the raw (unregulated) B+. The emitter of the switch is tied to common through pin 4 via RX3431. As the pass transistor is

switched on and off, pulses of about 400V are induced in the primary. When the transistor is on, energy is stored in the form of a magnetic field. When the transistor switches off, the collapsing field induces the pulse. Note the similarity between these pulses and the conventional HOT pulse.

Regulation in this supply

In this particular circuit, regulation is achieved through a form of pulse rate modulation. As the load increases, the pulse rate decreases while the duty cycle remains fixed. In other words, this is essentially frequency modulation because the pulse rate and width vary simultaneously. A lower pulse rate means a longer "on" time for the switch and more power imparted to the transformer. This acts to raise the transformer's output voltage.

An 80 V pulse from pin 11 of the switching transformer is half-wave rectified by CRX3433 and filtered by C3434. The resultant negative voltage is applied to the sense input, pin 1, of the voltage regulator. Since the various components in the IC work with Q3431 to determine the frequency of oscillation, a change in voltage at the sense input results in a change in the frequency.

A simple design

This is one of the simplest switching supply designs currently in use. There is no optoisolator in the feedback loop. All components associated with switching and regulation use the same hot ground used by the full-wave rectifier and input filters. There are no start-up or shutdown functions, the supply should run whenever the set is plugged in and should continue to run even if the set is in high-voltage shutdown.

Referring to the secondary side of TX3431, you will notice that there are a number of switches that activate various sources. Source No. 2, however, which supplies the HOT, is alive whenever the power supply is running. Source No. 5, which supplies HOR Vcc, is also up regardless of the state of the switches. It

Babbert is an independent consumer electronics servicing technician.

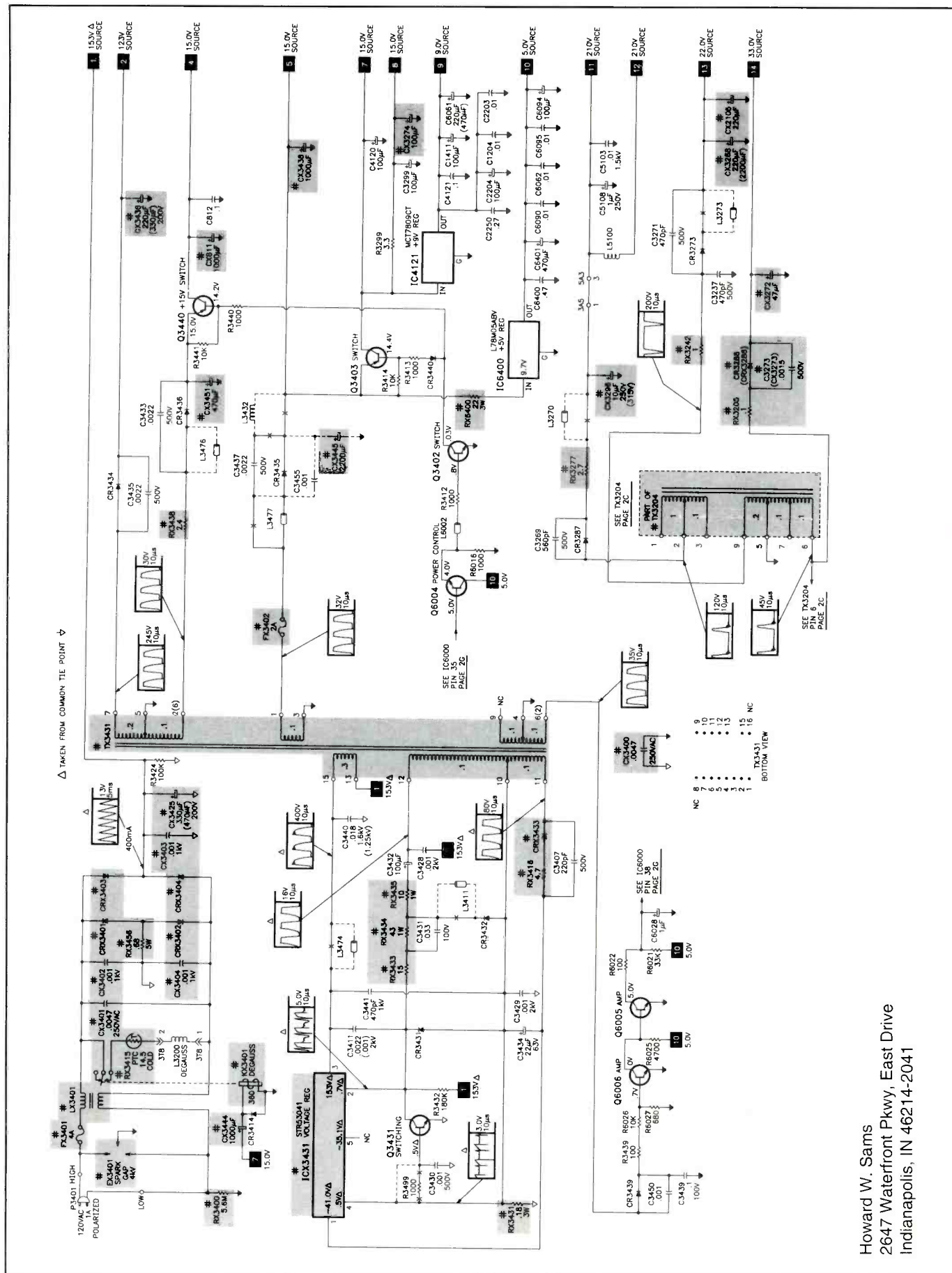

Howard W. Sams
 2647 Waterfront Pkwy, East Drive
 Indianapolis, IN 46214-2041

Figure 1. The switching power supply used in the Zenith television model SM2726EWM is somewhat unconventional in that it uses a linear regulator IC as part of a feedback oscillator to generate switching pulses.

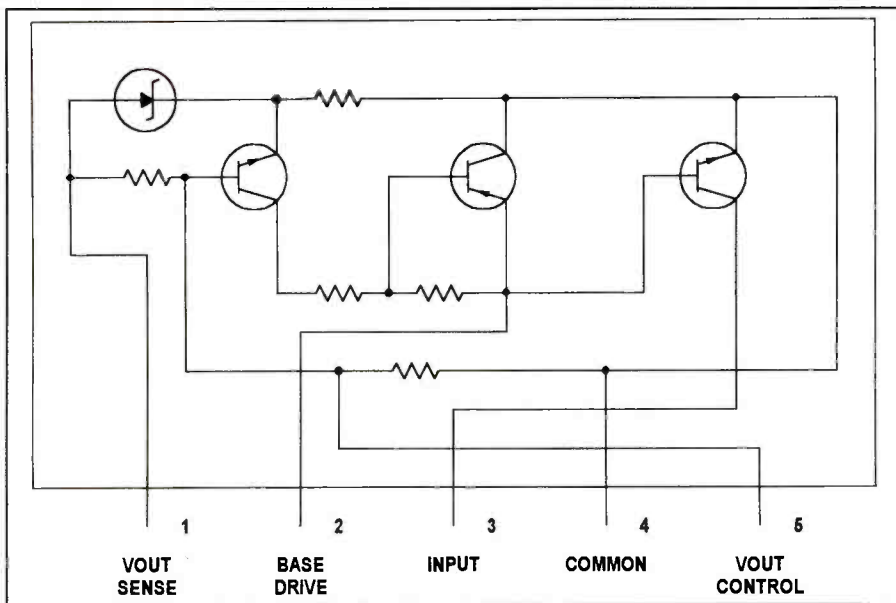

Figure 2. Integrated circuit ICX3431, an STR53041 linear regulator, is being used as part of a feedback oscillator circuit to generate the switching pulse required by the switching power supply.

would seem then that the horizontal output section should be running whenever the set is plugged in. This is not the case, as will be shown shortly.

Switch Q3403 is controlled by the syscon via switches Q6004 and Q3402. When the set is switched on, Q3403 conducts, activating sources 7, 8, and 9. Source No. 8 supplies the horizontal driver stage (not shown). In this unusual design, the horizontal output section is turned on and off by controlling power to the driver stage. When switch Q3403 is turned on by the syscon, the horizontal output section will start. Switch Q3440 is also turned on when the chassis is switched on. This switch feeds source No. 4, which is used by the audio output section.

As always, the syscon requires standby voltage to stay alive when the chassis is switched off. Standby voltage is provided by 5V regulator IC6400, a 7805 three-terminal regulator. This regulator is supplied from a tap just ahead of switch Q3403. RX6400 drops a portion of the input voltage to keep the regulator from dissipating too much power.

The scan-derived supply

The power supply schematic includes the portion of TX3204 (the IHVT) that is used for the scan-derived supply. Sources 11 and 12 supply the video output section, which requires a voltage somewhat higher than those provided by the switching supply. The vertical output

section, which requires a fairly substantial current, is powered by source No. 13.

You will notice that the HOT pulse shown on the schematic is inverted at pin 9 of TX3204 (source 13), whereas the pulse is right side up on pin 2. This is because there are two methods of deriving power from the IHVT. Getting the desired pulse polarity is just a matter of tapping a winding having the proper phase.

In true "scan" rectification, the half-wave rectifier conducts during scan time when the HOT and damper diode are conducting. This method is more suitable in applications where a heavier current is being drawn. In "flyback" or "pulse" rectification, power is taken from the inductive kick that results when the HOT switches off. This is more suitable for the generation of higher voltage. Both forms of rectification are usually referred to as scan-derived.

Troubleshooting

This switching power supply will be easy to service because it is capable of running continuously on its own. If the raw B+ (source No. 1) is okay, but there is no switching activity, then the voltage regulator or the switching transistor is probably defective. Note: if the regulator is switching, you will not be able to measure 153V at pin 3. The 400V_{pp} waveform, however, can be scoped. If you measure 153V, then the series-pass transistor in the IC is not switching.

Since the emitter, base, and collector of this transistor can be accessed via pins 4, 2, and 3 respectively, it can be tested like any other transistor. Of course, if it is shorted then the main power fuse, FX3401 will be open. Since the series-pass transistor handles the most power, it is the component most likely to fail in the IC.

If the IC seems to be okay, check Q3431 and all other components associated with this circuit; especially diodes, power resistors, and electrolytic capacitors. Don't overlook the possibility of open or shorted turns in TX3431. Ring testing may be necessary if you suspect shorted turns.

If the power supply is working normally, but one or more secondary voltages are missing, you will need to determine where the sources originate, and whether they are dependent on switches Q3440 and Q3403. If both switches are "off," then Q6004 or Q3402 must be bad, or possibly are not getting a turn-on signal from the syscon. Many of the secondary sources have fusible resistors before or after the half-wave rectifiers. Sources 5 through 10 depend on fuse FX3402 for overload protection.

Sources 9 and 10 are further regulated by 3-terminal regulators IC4121 and IC6400. These devices are very reliable because of their internal thermal shut-down feature, which protects against overloads. If you suspect that either is defective, wick-off the output pin and check for the proper output voltage, which can be found as part of the part number (e.g., 7805 is a 5V regulator).

If you encounter a situation in which the power supply appears to be too heavily loaded, all output voltages seem low or pulse amplitude is low, you will need to determine which source is being loaded. If loading only occurs after the chassis is switched on, then obviously the problem is in one of the sections supplied by Q3402 or Q3403. If loading occurs when the chassis is off, then the problem must be in an unswitched supply.

Loading of the scan-derived power supply will be reflected into source No. 2 since it supplies the HOT. Don't overlook the possibility that shorted or leaky filter capacitors in the supply lines might cause loading. If you suspect that a given supply is being made to source excessive current, look for low resistance paths to ground in the circuit that it supplies. ■

Recognizing VCR defects (from page 9)

Power supply integrated circuits

In cases in which a VCR is dead and nothing seems to work, the power IC is a good suspect. The power IC is the largest IC chip on the power supply board. Sometimes, it is the only IC on the board. If you check with your voltmeter, you may find that the 5V line on the IC is missing. Be sure to use an isolation transformer or ground fault circuit interrupter (GFCI) when working on power supplies.

Cassette carriages

When a tape is loaded, it is the job of the cassette carriage to carry the tape into the VCR and load it onto the drive path. If this important function is not performed properly, the VCR won't operate, or will operate improperly. Causes and symptoms of cassette problems include the following:

- You hear a clicking noise when power is applied or inserting a cassette.
- Cassette tray on carriage is crooked. If you are lucky, maybe a carriage gear just jumped a tooth.
- Cassette does not go all the way down.
- Cassette does not seat firmly on gaging pins after loading.
- You see broken pieces in carriage assembly.
- Cassette binds, or does not go in when you try to insert it.
- Cassette binds or gets stuck while loading under power.
- Cassette does not eject all the way.
- Cassette lid does not open. Cassette opener spring may have sprung.
- Cassette motor is defective.
- Someone forcibly removed a cassette that would not eject.

Any of the above is strong evidence the cassette carriage is defective. You always want to see if it's a simple mechanical problem you can fix without replacing the entire carriage assembly. This is not always possible. Some manufacturers don't even supply individual parts, just complete assemblies.

In situations in which the carriage binds, the carriage may have been bent by some heavy object on top of the VCR. Often, it can be bent back easily. In cases of broken parts, see if they can be repaired or glued if replacements are not available.

The easiest solution is to replace the entire carriage. It's an easy task on most VCRs. Most retail in the \$25 to \$35 range. I would not waste much time on trying to salvage one if knew I could buy a new one at these prices. But if it starts getting over \$40, you might want to try harder to salvage the defective unit.

Mode switch

The mode switch is a sensor that reports to the CPU. It senses all the positions of the moving mechanism. A typical VCR mode switch has three switches in a sealed unit (that is why it's called a switch). As the mechanism moves, the switches open and close at different intervals. The CPU sees this as three channels of pulsed data and can determine what position the mechanism is in from this. If this sounds a little complicated, all you really need to know is what the symptoms are when it fails.

Failure of the mode switch is caused by one or more of the internal switches not making reliable contact. This failure

affects the travel of the moving mechanism. Usually if the CPU gets bad data during loadup, it will issue an unload command. The tape appears to be loading normally and then mysteriously unloads.

Mode switch problems always start out intermittent, and progressively get worse. Sometimes, however, the mechanism will load up but stop in the wrong place without unloading. It may play at the wrong speed, the tension arm may not be correctly positioned causing picture distortions, or it might just shut off. Repeatedly pressing play may get it to work in early failure stages, but eventually it will fail completely.

The key symptom to look for is "incomplete travel of the moving mechanism." A simple test is to locate the master cam gear (usually the largest gear in the VCR) while the failure is still intermittent and see if it stops in the same place every time. Making reference marks (a magic marker is best) on the gear after pressing play and again after pressing eject makes this easier to see. Now load and unload the tape by pressing play and eject about 20 times (yes, this takes a while). If the gear stops in a different place just once, the mode switch is most likely defective.

Intermittent record timer

The following discussion assumes you can record manually.

The customer complains that when he programs the VCR to record his favorite TV show and later sits down to watch it, he discovers it didn't record anything at all. This can be frustrating. He assures you that he double checked the programming procedures and is positive he did it right.

There are actually very few problems associated with the electronic parts in timer circuits. What is very common are marginal mechanical defects. A marginal defect is one that occasionally occurs. You may have not even noticed it, but in manual modes, if you ever had to press RECORD more than once to get it to go, you have such a defect.

This type of problem can be caused by a variety of mechan-

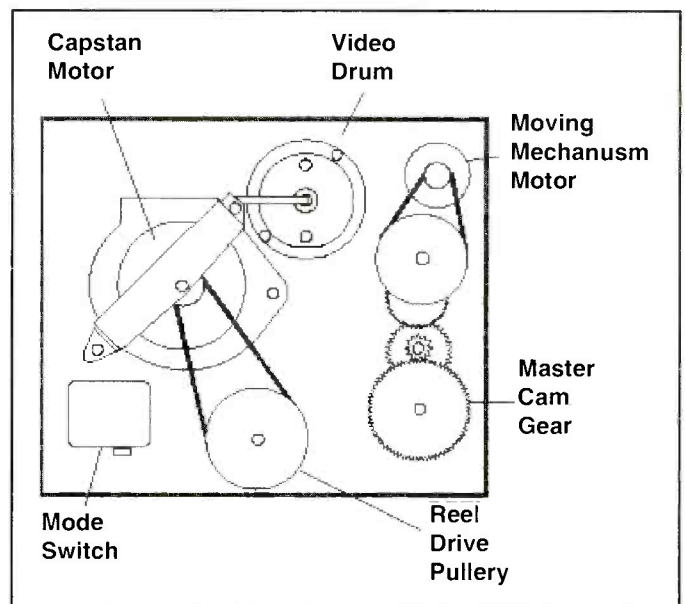

Figure 3. The bottom view of a typical VCR mechanism.

ical defects. Likely possibilities are mode switches, slipping load belts, marginally defective idlers, intermittent record safety switches, etc.

In the event that the record timer simply does not work and you are positive you are programming it correctly, it is most likely an electronic part failure (which is rare).

Top 10 VCR defects of the 90s

VCRs in the 90s are really very different from those made in the 80s. They are smaller, lighter, and have fewer parts. On some, you actually have to hold them down with one hand while you push the front panel buttons with the other to avoid pushing it off what ever it is setting on.

The mechanical decks are much lighter. Even though knowledge about plastic and its reliability are increasing, there is still a lot in the realm of the unknown that can happen.

Other changes have taken place. For example, you no longer have major problems with the idler. There are still a few spot problems on some brands, but for the most part the idler has become almost trouble free. Trouble with end sensors and reel sensors are also gone.

Nearly all VCRs now have features such as video muting, auto tracking, and real time counter; even the low end cheapies, since the mid-90s.

The antenna connectors are now part of a package that contains the modulator, tuner, IF board, and connection piece. If someone accidentally yanks off an antenna fitting, you have to fix it because this assembly is prohibitively expensive. If it is impossible to fix, the customer still has the option to use the VCR without the tuner to play back tapes.

These machines have problems that did not affect the older ones. Many of these newer VCRs have decks that offer limited access. For example, nearly every VCR before 1990 had an access plate on the bottom that allowed the technician to get to everything underneath easily. On newer VCRs, you have to pull the deck to get to the bottom side. With the deck out, the VCR usually can not be powered up for an operational check. Not much fun. Anytime you have a cassette stuck inside, you have really got your work cut out for you. Servicing of the newer VCRs can be tougher for the above reasons.

However, most of these VCRs can be fixed quickly and easily if you know what to do. Once you are armed with this powerful troubleshooting knowledge, you are in the driver's seat for making a lot of repairs. Just take the time to familiarize yourself with the parts in the VCR mechanical components section. No other experience is required.

The top 10 problems of the 90s are detailed below.

Ten Common Problems in VCRs made in the 90s

1. Dirty heads
2. Infrared diode
3. Belts
4. CPU reset
5. Capstan bearings
6. Antenna block
7. Foreign objects caught in mechanisms
8. Cassette carriages
9. Mode switch
10. Capstan pulley

Dirty heads

Nearly all VCRs made in the 90s have video muting. This causes the TV screen to go to a solid blue color if there is no video output. Often, video muting can make the problem of dirty heads more difficult to troubleshoot than it is on VCRs without this feature. The tough part is that there are other defects which can cause your monitor to go blue. Carefully looking at the following symptoms can quickly narrow it down.

- Sound is o.k.
- TV screen is solid blue.
- It happened suddenly. It did not start out a little snowy and get progressively worse over a period of months. Everything was fine and suddenly the picture went blue.
- Picture went out when tape got snarled up in the machine.

With these symptoms, if everything else is okay: the tape loads up and flows correctly, the video head spins, the reels turn, you have good sound, then it's most likely that the video heads are clogged. This happens most frequently when the VCR is used to play a lot of rented movies. It may be that a certain number of previous renters have defective VCRs that can put substantial amounts of contaminants on the tape. If the VCR owner then rented that movie, those contaminants have been picked up by his video heads.

The cure for this problem is to clean the heads.

Infrared transmitter diode

A common problem with VCRs of the mid to late 1990s, is the infrared transmitter diode. In the cassette sensing circuitry, this part transmits infrared energy to the tape end sensors. When the tape has played completely, or completely rewound, the infrared transmitter diode shines through the transparent tape leader, which signals that the VCR should either stop (if rewinding), or stop then rewind (if playing a tape, or fast forwarding). On older VCRs, it was the end sensors that were a common cause of failure. But on newer models, it is the infrared transmitting diode instead.

Common symptoms of this problem are that the VCR spits the cassette out as soon as you insert it. Usually, the VCR will load it up all the way but then issue an eject command. Other VCRs may let you see the movie for a while, and then suddenly it goes dead. On Funai, Hitachi, Magnavox, Philips, Symphonic, and Sylvania, the cassette ejects when you hit the power button after you noticed it went dead.

The cure for this problem is to replace the infrared diode.

Belts

Newer VCRs for the most part have fewer belts than their older counterparts. Most of them have fewer than three. There are no more flat belts on the capstan and the tiny counter belts have vanished entirely. Fewer belts does mean fewer belt problems, however, pesky problems can still occur when the rubber becomes marginal.

Belts can cause a number of symptoms depending on which belt is failing. First inspect for belts that may have broken or popped off. Then closely scrutinize for cracks or glazing. Next, check for elasticity by stretching them about 25% and see if they return to their original size. If in doubt, you may want to replace all of them. They are now inexpensive and easy to replace on most models.

Symptoms of belt problems include the following:⁴

- Reel belt — an early sign of reel belt weakness is when a T-120 cassette (6 hours) during rewind shuts off before it rewinds all the way. Cassettes with less tape operate normally. This belt causes few other problems.

- Tape load belt — this belt is by far the biggest troublemaker. The VCR may load tape around the video drum. At that point, insufficient traction results in not being able to complete the load cycle. The CPU then issues a shutdown command. Sometimes, these belts may squeal when slipping.

- Cassette carriage belt — rarely ever fails.
- Remember, rubber components degrade with age whether you use them or not.

CPU reset

This is the exact same problem that was discussed in the portion of this article about cassettes in the 1980s. And just as was the case with those older VCRs, you can cure the problem simply by disconnecting the ac power plug for about 30 seconds and then plugging it back in again. This resets the CPU.

Capstan bearings

The symptoms, troubleshooting, and cure of capstan bearing problems in VCRs manufactured in the 1990s are the same as for those made in the 1980s.

Antenna block

As with the antenna block problem described above for VCRs made in the 1980s, the symptom of this problem is that the coax connector falls off.

Nearly all VCRs made in the 1990s have the modulator incorporated inside the tuner. That means you have one of the tougher jobs on your hands. If this VCR does have a separate tuner and modulator, the discussion of the antenna block on VCRs of the 1980s, above, applies.

If the VCR has the modulator incorporated inside the tuner, even if you do have a good wholesale source for parts, you are still going to pay at least \$70 to \$80 or more for this part. In other words, you are going to have to fix the modulator in order to allow the customer to use the VCR the way he does now. If you cannot fix it, the customer can still use the VCR with the direct video jacks instead. Most of the newer cable boxes and TV's have them. If the TV does not have direct video jacks, you can use an external modulator instead.

To correct this problem, pull the Tuner-Modulator assembly out of the VCR. It is a lot less crowded when this is the only part on your bench. Remove the covers. You will need a soldering iron that is hotter than what you would use for circuit soldering. Using solder wick, unsolder all points on the board that connect to the frame. If the solder wick has a tendency to stick to the frame, you may need a hotter iron. Also unsolder any points that connect to fittings. Remove the board. Install the new fitting, then reassemble in reverse order.

Foreign objects caught in mechanisms

The cause and cure of this problem was discussed above in the section on 1980s VCRs.

Cassette carriages

See the discussion of cassette carriages above.

Mode switch

See the discussion of mode switch above.

Capstan pulley

Beneath the Capstan motor is a pulley for the belt that goes to the reel drive mechanism. This pulley cracks and can do many strange things. When it falls off, it is easy to figure out. But before it does, be on the lookout for these symptoms:

- Rewind can be intermittent.
- Rewind may not work at all.
- The search mechanism can behave strangely. Check the operation of the pause and search keys.
- The VCR may eat tape.

Inspect the pulley for a crack. Most of the time, there is only one. As time goes on, the pressure that holds it on gets weaker until eventually it pops off. Most manufacturers only supply the complete capstan motor assembly. An economical way to fix this is with epoxy glue (not super glue). You will have a pulley with a crack in it, but it does not seem to cause any problems during operation.

The more things change . . .

As evidenced by problems/symptoms/cures discussed in this article, changing designs of VCRs have eliminated some common problems, introduced some new common problems, and left some problems unchanged. Troubleshooting of these products is made easier and more efficient by becoming aware of the problems that are most common in an generation of products.

VCR cleaning

VCR cleaning really isn't much different than doing the dishes. Some dishes simply rinse clean while others you may have to scrub and scrub to get clean. VCRs are the same. No two VCRs get dirty alike and like dishes, some clean up real easy while others need to be scrubbed hard.

VCR cleaning is usually performed:

- 1.) at a regular maintenance interval
- 2.) after experiencing a phenomenon known as a head clog.

Usually it occurs suddenly as the result of foreign matter sticking to one or more of the video heads. This results in a sudden snowy picture (it occurs mostly on rental tapes). The snow is uniform or spread evenly across the screen from top to bottom. The sound is usually not affected at all or at the most it may have a slight distortion in it.

The most important tools for the job are chamois tipped cleaning sticks, cotton swabs, and head cleaning fluid.

The term video heads and video drum are sometimes used interchangeably, but they are different. The video drum is the large tilted assembly the tape wraps around and is divided into two halves. The lower stationary part is known as the lower drum. It consists of the servo motor that spins the upper half, known as the upper drum. As you rotate the upper drum by hand, the slots you see at the bottom of it, are the video heads. They are the tiny electromagnetic coils that do the actual reading and writing on the tape. They are very fragile. Never touch them with your fingers or a Q-tip. Only touch them with a chamois stick while cleaning and then only in a horizontal direction, relative to the orientation of the head drum.

Cleaning the video heads

In the event of a head clog, the first thing to do on a cleaning job is to restore the picture. Cleaning the video heads is the most critical part of the process. Use extreme caution. Never use cotton swabs. Cotton tends to grab, get caught, or leave fibers in the heads. It can also break them. Using chamois sticks is by far the safest method.

Soak a chamois stick with head cleaning fluid and place it directly on a video head with light pressure. Hold the chamois stick stationary in one hand and rotate the drum clockwise with the other. You want all scrubbing action to be in a horizontal direction. Never use any vertical motion; it's very risky for head tip breakage. When finished, allow a minute or two for the heads to dry and you're ready to try it out.

Pop in a tape and press PLAY. Confirm that the picture is now clear. If not, you might want to repeat the above process once again. Ninety eight percent of the time, cleaning the video heads solves this symptom. Most of the remaining two percent is caused by a defective video head.

Finishing the job

The video heads are clean. Now you need to finish the video drum. Keep a little distance from the delicate heads and continue to scrub with horizontal motion. Should you accidentally contact a head while scrubbing vertically, your chances are about 100 times greater for causing damage. When cleaning the lower drum, always rotate the upper drum to keep the heads as far away as possible from wherever the cleaning stick is. Be sure to give special attention to all areas where the tape contacts the drum.

Next, clean everything else in the tape path. From here on the rules are much more relaxed. The only thing you need to be careful about is getting any fluid on belts or rubber tires. Head cleaning fluid is still a good choice for everything left. Starting with the supply reel table, clean off any dust. Give special attention to where the idler and brakes make contact with it as well as the brakes themselves. Then, in the same direction the tape flows, clean the guide post, tension arm, full erase head, impedance roller (if any), guide rollers and angle pins, audio heads, guide post, capstan shaft, half load arms or review post (if any), and finally the take-up reel table and brakes.

The capstan shaft always seems to collect most of the debris. Most of the buildup is an oxide material that comes from the tape. You want to be sure when cleaning it, that you use minimal cleaning fluid on the swab to help keep it from going down into the capstan bearing. Most of the time this shaft cleans right up, but sometimes buildups can be stubborn. Don't be tempted to scrape the gunk off with something hard like a knife or screw driver. If the buildups won't come off after persistent scrubbing, try soaking the capstan shaft with any lubricating oil and set it aside for a few hours, preferably overnight. The oil will penetrate and loosen the oxide material making it much easier to remove. Don't forget to thoroughly clean the oil off when finished.

Cleaning belts and pulleys

Despite what you may hear or read about, the only fluid you want to use on rubber are special rubber cleaning solvents. Other cleaning solutions can dry out and harden the

belts. The cost of belts nowadays is very inexpensive anyway so you may find the price of a replacement belt kit for the VCR is probably less than a bottle of rubber cleaner. But first it is important to clean the pulleys. Many service centers tend to skip this part, but the fact is, dirt on the pulleys reduces torque. Torque tests confirm that even slight amounts of dirt on the pulleys can reduce the torque by at least 50 percent. With the belts off, take a moistened swab, place it in the pulley's groove and spin it until no more dirt comes off. Repeat the process with all pulleys.

Cleaning deck floor and circuit boards

If there is any dust on the floor of the mechanical deck or circuit boards, it should be removed. It's best to use a soft brush and a vacuum cleaner. Do not touch any parts with the vacuum. Use the brush to dislodge or loosen the dust the vacuum cleaner can't get. If the dirt is stubborn, the swab and cleaning fluid method might work better. In any case, be sure to remain clear of any adjustment controls on the circuit boards. Accidentally misadjusting any of these controls can mean a lot more work to get them adjusted properly again.

Using compressed air

Use compressed air to blow dust out of your VCR. To be on the safe side, you may want to observe the following:

- Use only enough air pressure to remove the dust.
- Use sparingly on the mechanical deck. There is grease in numerous places on the deck and you don't want dust sticking to it. Also you don't want to risk blowing lubricants out of any VCR bearings.
- On circuit boards, blow dust away from mechanical deck.
- Just concentrate on getting most of the dust out. Spending extra time to get absolutely all of it out is not recommended. You want to minimize the exposure to the air blast as much as possible.

The dummy cassette

In the early years of VCR servicing, there were no dummy cassettes. Those of us in the VCR servicing community can hardly believe what it was like to repair VCRs without one of these things. I don't know how we ever managed to get by. I do know that we sure mangled a lot more tapes and did a lot more guess work because it was nearly impossible to see what was going on underneath the cassette. If you can't see it, you can't fix it. Or at least it's a lot more difficult to figure out.

There were a few VCR models that you could put into a troubleshooting mode and operate without loading a cassette, but they were far and few.

Well, things certainly have changed. Today you can pick up a dummy cassette for just a few bucks. It takes less than a minute to load one up and put the VCR through a few functions. You get valuable troubleshooting clues in seconds. When you need to get a good look at what is going on, this tool will certainly let you see it.

What is a dummy cassette?

Basically, a dummy cassette is a plastic frame that loads like an ordinary VHS cassette. It fools the VCR into thinking it's a

real cassette. It trips all sensors and switches required to put the VCR into any mode of operation. For starters:

- It has very large holes in it. This makes it possible to see through it to observe what is going on under the cassette. This is excellent for verifying things like brakes, idlers, levers, tension arm, tension band, carriage parts, and various linkages are doing what they are supposed to.

- Since it doesn't have any tape in it, there is no need to worry about damaging any.

- Gives you access to the reel tables so you can get a feel by hand if there is adequate torque to turn the reels.

- When troubleshooting, it gives you the best look at what's going on without a regular cassette to obstruct your view.

Even for beginners, this device can save troubleshooting time significantly. The few dollars you spend on this tool, will more than make up for it in fewer headaches and easier diagnosis. Dummy cassettes are available from any distributor that sells products for consumer electronics product servicing.

What to do when the cassette won't eject

Trying to remove a cassette from a defective VCR without knowing what you are doing can be risky. A VCR can be easily damaged beyond repair if you force something that doesn't go your way. In this section, you will learn the correct and easy way to remove cassettes from malfunctioning VCRs without causing further damage. Check the service manual.

The Fixer Corp. website features a database that contains solutions to the no-eject problem for many VCRs. You might check the database page for the particular VCR and the online service manual. Most database pages also have a section with details for that model number on manually ejecting cassettes.

Many times, a VCR will fail with a cassette still in it. Unfortunately, when it's about to malfunction, it doesn't say to itself "Uh oh, I have a cassette inside. Better eject it before I drop dead." Although that would be nice, we need to deal with reality. There are many defects that can prevent the eject operation from functioning. This can be very frustrating. Especially if the cassette is a rental that needs to get back to the video store; immediately.

Some general tips on removing a stuck tape

First, there is a simple thing you can try that hardly takes any time at all. Pull the power plug on your VCR for about 30 seconds; and then plug it back in again. This sends a reset pulse to the CPU. If the problem was that it was locked up, this procedure will fix it. CPU lockups are caused by ordinary household static electricity and power surges.

If this approach is unsuccessful, you'll need to open the VCR to manually eject the cassette. Be sure it's unplugged first.

Most of the time, this is a simple job that can be accomplished by a process called hand cycling. Hand cycling is a procedure in which you find the motor that operates the mechanism you want to function and rotate that motor shaft or pulley with your finger to operate the system. The whole process is divided into three steps:

1. retracting the roller guides to the unloaded position,
2. reeling in the tape,
3. operating the cassette carriage to eject the cassette.

If the tape is already unloaded you can skip steps 1 and 2 and go directly to step 3.

To make your task easier, most database pages can tell you if one or two motors are involved and where they are located. The Moving Mechanism motor operates the Roller Guides while the carriage motor raises the cassette. Sometimes one motor performs both of these functions.

Retracting roller guides

Once the Moving Mechanism motor is located, begin hand cycling the mechanism. If there is a worn gear in the mechanism, you must hand cycle somewhere between the motor and that gear. Usually the shaft or pulley that comes out of the motor is the best place. Continue hand cycling while watching the master cam gear if you can. It should move a little bit every time you turn the motor. You may have to hand cycle quite a ways before you see roller guides retracting. If you run into resistance instead, you may be at one end of the mechanisms travel; which means try going the other way.

Reeling in the tape

The Moving Mechanism motor will retract the guide rollers but usually will not reel in the tape. The tape needs to be reeled in because the cassette lid is forced shut as the cassette is raised. This will wrinkle the tape. Sometimes from the bottom, you can operate the idler and reel drive pulley together to do that. If that doesn't work, try hand cycling the moving mechanism motor until the roller guides come out of the cassette just a little. This might be enough for the idler to engage the reel tables. If nothing else works, see if you can get to one of the reel tables directly. If so, you can manually turn one of them to get the tape in. If unsuccessful, you may have to eject it that way. If you're careful, the tape will only suffer a minor wrinkle, which is no big deal.

Manually operating the cassette carriage

Next, locate the motor that powers the cassette carriage. If there is a worn gear in the mechanism, you must hand cycle somewhere between the motor and that gear. Once again, the shaft or pulley that comes out of the motor is usually the best place. Try hand cycling in one direction until you see the carriage start to rise. If you run into resistance instead, try going the other way. If you see the carriage rising, you are going the right way, so keep going. Don't try to take the short cut to remove the cassette before it's all the way out. This could damage the lid release plunger. Continue hand cycling until the carriage hits the end of its travel.

If you run into resistance in both directions while performing any hand cycling operation, chances are that you have something broken in the mechanism. Although this may prevent you from getting the cassette out for now, at least you may have found the source of your problem.

Remember, don't get shortsighted. The bottom line is *don't force anything* or it may wind up in VCR heaven. You already have one problem causing the no-eject symptom. Don't add to your list of troubles. Forcing the cassette out can give you a second problem, a ruined cassette carriage, which is sometimes an expensive part to replace. ■



ES&T Presents Computer Troubleshooting & Repair

Features information on repairing Macintosh computers, a CD-ROM primer, and a color monitor. Also included are hard drive repair tips and computer diagnostic software.
61087 • \$24.95



Computer Monitor Troubleshooting & Repair

Learn the basics of computer monitors with chapters on tools and test equipment, monitor types, special procedures, how to find a problem, and how to repair faults in the CRT.
61100 • \$34.95



1999 Computer Monitor Troubleshooting Tips

Includes over 2,000 troubleshooting and repair tips listed by manufacturer name and model number featuring such major names as Apple, Gateway, Compaq, IBM, and Dell.
CD-ROM Included
61179 • \$49.95



ES&T Presents the Test Equipment Guide

Includes the latest information on how to choose the best equipment, how to build test equipment and accessories, how to set up the ideal service bench, and how to put together a practical tool kit.
61089 • \$24.95



Complete VCR Troubleshooting & Repair

In addition to troubleshooting procedures, this book contains nine detailed VCR case studies, each focusing on a particular model of VCR with a very specific and common problem.
61102 • \$34.95



Semiconductor Cross Reference, 4th Edition

With more than 490,000 part numbers, type numbers, and other identifying numbers listed, technicians will have no problem locating the replacement or substitution information needed.
61080 • \$29.95
Also available on CD-ROM.
61140 • \$29.95



ES&T Presents TV Troubleshooting & Repair

Presents important and new information that will make it possible for technicians, students, and electronics hobbyists to service TVs faster, more efficiently, and more economically.
61086 • \$24.95



Complete Projection TV Troubleshooting & Repair

Covers everything from the basics of projection circuits, tools and test equipment, TV types, safety procedures and measurements, to the finely detailed repair techniques.
61134 • \$34.95

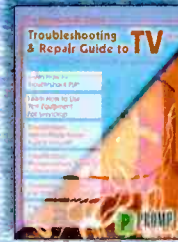

Troubleshooting & Repair Guide to TV, Second Edition

The most comprehensive complete, and up-to-date television repair book available, with tips on how to troubleshoot the newest circuits in today's TVs.
61146 • \$34.95



ES&T Presents VCR Troubleshooting & Repair

This book provides in-depth and thorough information on a variety of VCR troubleshooting and repair areas.
61158 • \$24.95



Howard W. Sams Servicing Series RCA/GE Televisions

From RCA component numbering systems to the infamous "tuner w/tp" problem, this book gives you all you need to make more efficient repairs.
61171 • \$34.95

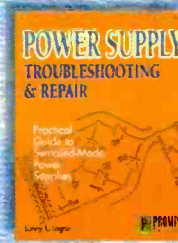

Power Supply Troubleshooting & Repair

Designed to provide technicians with a better understanding of how switched-mode power supplies operate. It also provides practical, useful procedures to follow when troubleshooting power supplies.
61138 • \$24.95

YES! I want to learn from the experts. Rush me my book(s) right away!

Please add \$4 shipping & handling. **FREE** shipping & handling for orders \$50 and over. Please make your check or money order payable to: Electronic Servicing & Technology U.S. and possessions - add \$4 shipping/handling. FREE S/H on orders \$50 and over. Foreign - shipping/handling charges are calculated by order weight & destination. A \$4 credit will be applied for Foreign orders over \$50.

To Order Call
800-853-9797

Qty	Order#	Description	Price	Total Price
Shipping/Handling				
New York Residents add applicable sales tax				
Total				

Name _____

Address _____

City _____ State _____ Zip _____

MC/VISA/AMEX/Discover # _____ Expires _____

Form of payment: MC VISA AMEX Discover Check Money Order

Please mail your orders to: Electronic Servicing & Technology, 25 Newbridge Rd., Hicksville, NY 11801-9962 FAX: 516-681-2926

Classified

Classified advertising is available by the word or per column inch.

By-the word. \$1.65 per word, per insertion, pre-paid Minimum charge is \$35 per insertion. Initials and abbreviations count as full words. Indicate free category heading (For Sale, Business Opportunities, Miscellaneous, Wanted). Blind ads (replies sent to ES&T for forwarding) are \$40 additional. No agency discounts are allowed for classified advertising by the word. Contact Alycia Nichol森 at 516-681-2922 to place your classified ad (by-the-word). Mastercard, VISA, American Express and Discover are accepted for FAX or mail orders.

Per column Inch (classified Display): \$235 per column inch, per insertion, with frequency discounts available, 1" minimum, billed at 1/4" increments after that 10" maximum per ad. Blind ads are \$40 addition. Reader Service Number \$25 additional to cover processing and handling costs. (Free to 4-inch or larger ads.) For more information regarding classified display advertising, please call 630-584-5333. Optional color (determined by magazine) \$150 additional per insertion.

Electronic Servicing & Technology
25 Newbridge Rd, Hicksville, NY 11801 Attn: Classified Department
Ph: 516-681-2922 FAX: 516-681-2926

FOR SALE

TEST EQUIPMENT FOR SALE: REASONABLE PRICES SENCORE, TEKTRONIX, HP and MUCH MORE. View complete list at: <http://www.astglobal.com> or contact: **AST GLOBAL ELECTRONICS.** Voice: 888-216-7159; Fax 814-398-1176; e-mail: sales@astglobal.com

All VCR Drop In Power Supplies Rebuilt, \$29.95. Free Shipping. Liberty Electronics, 207 W. Clinton Avenue, Oaklyn, NJ 08107. 856-854-4443. E-mail jkliberty@aol.com

'nControl!@ COST-EFFECTIVE SOFTWARE
The **most complete** package tailored for service centers. Has features you won't see anywhere else! From \$49/mo. **Download free trial** <http://ServicerSolutions.com> (888) PBS-6288

WinSTIPS! — 132,000 Current tips from repair shops! All brands. Monitor and Consumer Electronics. Search any phrase. Vccross, Sams, Philips Ecg. One-button update Tips. Windows 95/98 **\$149.95.** (CD or Web download). <http://www.kdtviwe.com>. KD TV 514 3rd St., Aurora, IN 47001. **1-888-KD-STIPS.** All c/cards. Ken Hull C.E.T. These tips are GREAT! See them all BEFORE you buy!

ServiceTalk & MonitorTalk. Email repair group. Why work alone? 30 day free trial. <http://www.kdtviwe.com>

PRICE REDUCTION. Diehl Mark III \$29, Diehl Mark V Horizontal circuit tester \$139. Conductive coating for remote control keypads \$9.99 ppd. **WEEC, 2411 Nob Hill Road, Madison, WI 53713. 608-238-4629. Website:** <http://sites.netscape.net/duaneconger>

SENCORE, TEKTRONIX, HEWLETT PACKARD (all models). We **BUY, SELL, & TRADE.** Please call "**CHOICE ELECTRONICS**" for all of your test equipment needs. Complete financing options available. Call 1-800-609-0677, 605-361-6386 ask for Lance Tople.

FOR SALE

TV CASE HISTORIES: Volume 8 with 3,325+ histories. Satisfaction assured. Only \$59.75 (plus \$3.25 shipping). Over 9,700 books and supplements sold with only 1 returned for a refund! **Mike's Repair Service,** P.O. Box 217, Aberdeen Proving Ground, MD 21005. Same mailing address 36+ years. Send SASE for samples. 410-272-4984, 1-800-2-FIX-TVS 11a.m.-9 p.m. (<http://mikesrs.webjump.com>)

TEST EQUIPMENT BOUGHT & SOLD: OSCILLOSCOPES, ETC. 925-706-0177. FAX: 925-706-0156. www.oscilloscope-setc.com

*******NAP Tuner 340309******* RCA Tuner TCHRIA or TCCRIA and more. Snowy picture? **Will rebuild for \$25.00,** Free Shipping!!! **Tip Top TV & VCR,** 18441 Sherman Way, Reseda, CA 91335, **818-345-1974.**

****FREE** Service Tips for TV's, VCR's, Projection TV's, CAM-CORDER's.** Must have IBM compatible computer. Send your Name and Address to: **FREE SERVICE TIPS, P.O. BOX 464, WHEATLEY HEIGHTS, NY 11798.**

BUSINESS OPPORTUNITIES

ELECTRONIC SERVICE CENTER For Sale. Metro Detroit Area. Established over 30 years. (50K) 734-728-0618.

CENTRAL FLORIDA TV/ELECTRONICS Business/Building. Heart of the retirement area. 36 years (75K). Owner retiring. **941-385-0359.**

WANTED

WANTED:USED TEST EQUIPMENT. TURN IDLE OR EXCESS EQUIPMENT INTO CASH. AST GLOBAL ELECTRONICS. Voice: 888-216-7159; Fax 814-398-1176; e-mail: sales@astglobal.com.

Reader's Exchange

Readers' Exchange is a free service.

The following restrictions apply to Readers' Exchange:

- Only individual readers may use Readers' Exchange, and items must be restricted to those that are ordinarily associated with consumer electronics as a business or hobby. If you're in business to sell the item(s) you want to offer for sale, the appropriate place for your message is in a paid advertisement, not Readers' Exchange.
- Readers' Exchange items must be restricted to no more than three items each for wanted and for sale.
- All submissions must be typed or printed clearly!

Send your Readers' Exchange submissions to:

Readers' Exchange, Electronic Servicing & Technology, 25 Newbridge Road, Hicksville, NY 11801

Phone: 516-681-2922 Fax 516-681-2926

FOR SALE

Sencore VA62A universal analyzer, \$600.00. Like new with all manuals and accessories. *Contact: Dan, 218-643-9614, after 5:30 p.m.*

RCA modules, Syl. panels and def. Sams photofact. *Contact: Ann Bichanich, 15 W. Lake Street, Chisholm, MN 55719, 218-254-4421.*

Signal generators with cables, \$25.00 and up. *Contact: Sidney Goldhor, 510-357-3788.*

Various Thompson ESI CD's 97-98. Tifs 3.5 disks 96-97. Datatech 2 Tips 3.5" disks. Send SASE for list. Best offer. *Contact: Alan Durrenberger, Box 574772, Orlando, FL 32857.*

B&K 40 picture tube restorer and tester, 3 meters, like new, \$299.00. Heathkit picture tube tester, 3 meters, good condition, \$175.00. Two Beckman 350 digital VTVMs, \$90.00 for both. Hickok tube tester #799, excellent condition, \$299.00. Sams Photofacts. AR-TR-CB-MHF, \$5.00 each. Quality radio tubes, new sweep tubes. *Contact: Maurer TV Sales, 29 South 4th Street, Lebanon, PA 17042.*

WANTED

Navy impedance bridge ZM 11/U working or not. *Contact: Sidney, 510-357-3788.*

Crosley Model 124 radio 355Ω and 900Ω flexible resistor output transformer. *Contact: Paul Williams, 717-786-3803.*

KIKUSUI oscilloscope model COS6100M schematic/service manual. *Contact: Neville Young, 214 East Robertson St., Brandon, FL 33511.*

Used picture tube rebuilding equipment and accessories. *Contact: 408-251-1240, 408-223-6214, fax: 408-272-7339, steven1@hotmail.com.*

Heath scope Model 10-12E service manual. Will pay \$20.00 plus postage. *Contact: Ernie Corrado, 603-774-7864.*

Hitachi Model HTA 3000 service literature. Copy o.k. *Contact: Richard Gilman, P.O. Box 633, King City, CA 93930, 831-385-9248.*

Zen Model 9-815-04 for projection TV PV4653H. Working condition. Will pay \$25 plus shipping. *Contact: Frank, 6057 Providence Road, Virginia Beach, VA 23464, 757-523-8946.*



COMPLETE YOUR COLLECTION TODAY!

When ordering back issues include the following information: Name, address, city, state & zip. Please make a list of the issues you're requesting. When paying by credit card send the number along with the expiration date. Check, Money Order, Master-card, VISA, Discover and AMEX accepted.

**For Fastest Service
Fax 1-516-681-2926
Electronic Servicing & Technology
25 Newbridge Road, Hicksville, NY 11801**

Do You Repair Electronics?

Repair Databases for
TV, VCR, Monitor, UL
Audio, FCC, and more.

- Over 76,000 records
- Private user forums
- Live on-line chat rooms

RepairWorld.com

Electronix Corp. | 1 Herald Sq. Fairborn, OH 45324 (937) 871-2878

Circle (63) on Reply Card

Monitor Test Equipment

- Sweep rates to 64kHz
- Gray Scale/Color Bars & More
- "AutoScan" (auto rate switching)
- Portable & Bench units
- TV/Stereo/S-Video Products

LOW COST

CMM 1-800-466-4411, 770-662-5633

www.computermonitor.com

Visa-MC-AMX-Discover—On-line ordering

Circle (61) on Reply Card



VANCE BALDWIN
ELECTRONICS

Original Parts!
Printer
Consumer
Fax

Pricing!
Availability!
Research!
Place Orders!

E-Parts Online

Electronic Parts Online

www.vancebaldwin.com

Circle (70) on Reply Card

The nation's one source for brand name electronics parts, accessories and literature from

a z



Tritronics
INCORPORATED

aiwa PHILIPS
Betty Crocker
DENON
FISHER
GENERAL ELECTRIC
HITACHI
JVC
MAGNAVOX
Panasonic

REGA
SANYO
SHARP
SONY
TOSHIBA
WELBILT
ZENITH

1-800-638-3328
1-800-888-FAXD

Circle (69) on Reply Card



MOVING?

If you're planning a move in the near future, don't risk missing an issue of Electronic Servicing & Technology. Please give us 6-8 weeks notice if you're planning on changing your address. Just write your new address and mail it, WITH YOUR SUBSCRIPTION MAILING LABEL, to:

Electronic Servicing & Technology
25 Newbridge Road, Hicksville, NY 11801

Advertisers' Index

Company	Page Number	Reader Service Number	Advertiser Hotline
CEMA.....	IBC	58	703/907-7670
Computer & Monitor Main.....	64	61	800/466-4411
Custom Data Associates.....	43	60	800/451-0137
Electronic Design Specialist.....	13	62	561/487-6103
Electronic Servicing & Tech.....	61		800/853-9797
Electronics Technicians Assoc.	43	64	800/288-3824
Electronix Corporation.....	64	63	937/878-1828
Iscet.....	24	65	817/921-9101
Jesse Jones Industries.....	24		800/825-6690
Network Technologies.....	9	66	800/742-8324
Sams & Company, Howard.....	39	7	800/428-SAMS
Sencore.....	IFC	1	800/736-2673
Thomson Consumer Elec.....	BC	67	800/336-1900
Tritronics, Inc.....	64	69	800/638-3328
Vance Baldwin.....	64	70	800/432-8542

We'd like to see your company listed here too. Call Kaprelian & Company at 630-584-5333 Ext 18 to work out an advertising program tailored to suit your needs.

What's Your Best Servicing Value?

The magazine that makes money for you –

ELECTRONIC

Servicing & Technology



Each month, *ES&T* brings you how-to service articles on TVs...VCRs... Computers... CD players... Microwaveovens... Audio products and more. It's the information you need to do your job everyday.

Regular columns and special features from experts will make you more efficient – and more profitable – in no time. Plus, our monthly PROFAX, a FREE 8-page pull-out of popular TV, VCR and computer schematics, makes *ES&T* an even greater value.

1-year, (12 issues) \$26.95

1-year Canada/Mexico \$36.95

1-year Foreign Air Post, \$44.95

2-years, (24 issues) \$49.95

2-years, Canada/Mexico \$69.95

2-years Foreign Air Post, \$85.95

Electronic Servicing & Technology

25 Newbridge Road, Hicksville, NY 11801 • Phone: 516-681-2922 • FAX: 516-681-2926

Education For The Digital Universe

The Consumer Electronics Association (CEA) fosters technical excellence within the service and educational electronics community. To ensure that electronics professionals are up to date on cutting-edge technological advancements, we provide a variety of resources.

Preparing for the Future of Electronics, we offer:



THE CERTIFIED ELECTRONICS ASSOCIATE EXAM

- A high-technology certification exam for Electronics Professionals
- Industry-Supported Certification

Call Sylvan Prometric to register for the exam at a testing site near you: 800 722 2857

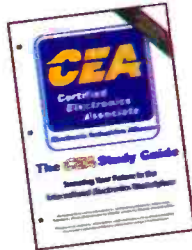

THE CEA STUDY GUIDE

- Includes student version of "Electronics Workbench™" CD-ROM with review modules and sample exams
- A comprehensive, interactive, study guide designed to help individuals prepare for the CEA Exam, 860 pages

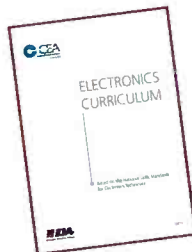

ELECTRONICS CURRICULUM 2000 EDITION

- Supports *National Skills Standards for Electronics Technicians*
- Nationwide standard for electronics instructors
- Prepared and reviewed by industry and academia



EDUCATIONAL TOOLS

- *National Skill Standards for Electronics Technicians*
- Electronics Program Accreditation
- Sponsorship of SkillsUSA - VICA "Electronics Applications" Competition
- Valuable Electronics Textbooks and Videotapes

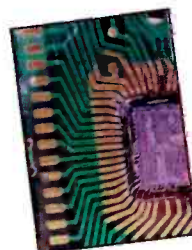

NATIONAL WORKSHOP AND TRAINING PROGRAMS

- Hands-on technical training for educators and technicians
Courses include:
 - PC Networking and Repair
 - DVD Training
 - DTV Technical Seminars
 - Computer Monitor/TV Servicing
 - And more

Ask About our New Electronics Career Video "No Limits"

For information and ordering, please contact the TES Department. Be sure to request your **FREE** Resource Catalog for Electronics Technicians and Educators!

Visit our web site at: www.CE.org



TECHNICAL EDUCATION & SERVICES DEPARTMENT
2500 Wilson Blvd., Arlington, VA 22201-3834 USA
703 907 7670 tel • 703 907 7968 fax • tesdept@CE.org
Circle (58) on Reply Card



Video Heads Pick A Number Any Number

When you're looking for a replacement head, SK Series is way *ahead* of the competition.

SK Series replacement video heads cross over to 4,500 different models and 68 different brands.

And when you're in need of any exact semiconductors, belts, tires, flyback transformers or video replacement parts, we have them too.

But we don't stop there.

Every SK Series product comes with the quality assurance and accuracy you expect from all Thomson products.

For more information on SK Series products, contact your nearest Thomson Distributor.

SK Series...The parts you need to do the job. "Trust me!"

 THOMSON CONSUMER ELECTRONICS

SK
Series

Circle (67) on Reply Card